

Physical Layer Driven Protocol and Algorithm Design for Energy-Efficient Wireless Sensor Networks

**Eugene Shih, Seong-Hwan Cho,
Nathan Ickes, Rex Min, Amit Sinha, Alice Wang,
Anantha Chandrakasan**

<http://www-mtl.mit.edu/research/icsystems/uamps>





Sensor Network Applications



Indoor Home Sensing



Equipment Monitoring



Medical Monitoring

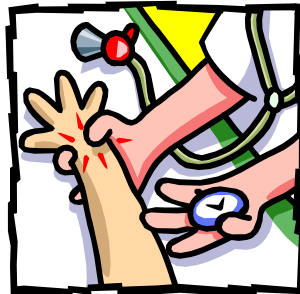

Vehicle Tracking

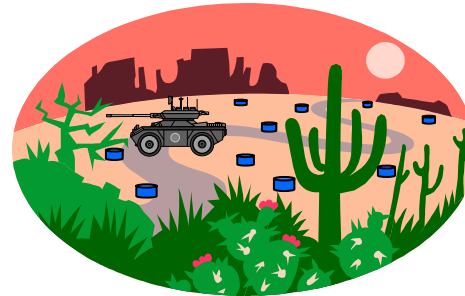

Design a **universal substrate** for data gathering in a massively distributed wireless sensor network



Domain Characteristics

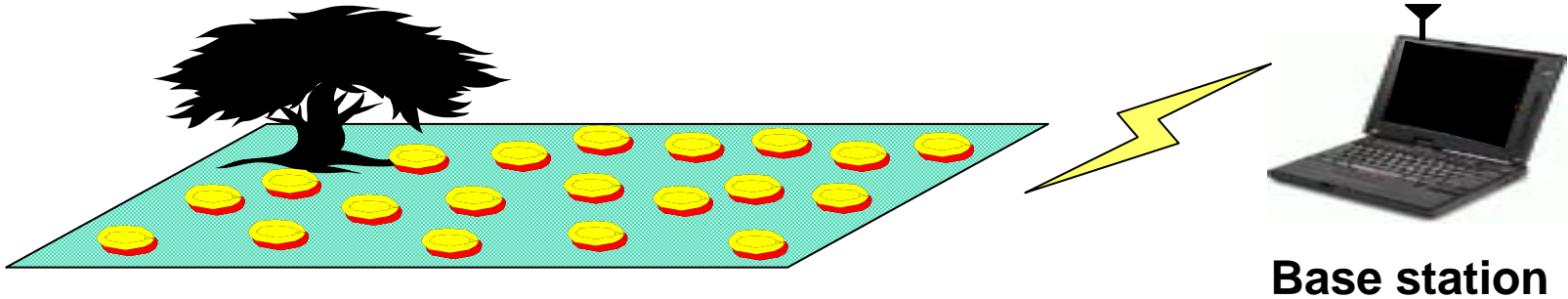

■ Node properties

- Compact form factor (1 cm^3)
- Low rate sensing ($< 10 \text{ kbps}$)
- Immobile

■ Network properties

- 100s to 1000s of nodes
- Small inter-node distance
- Network far from base station
- Hard-to-access

Compact form factor + Long lifetime →

Need Energy-efficiency



Power-Aware Design



- Conditions and requirements are time-varying
 - Input statistics
 - Tolerable latency
 - Environment
- Power-aware design exploits these variations
 - But maintains application requirements
- **Must pervade all system layers**
 - Hardware hooks necessary
 - Upper layers utilize hooks



μAMPS Node Architecture

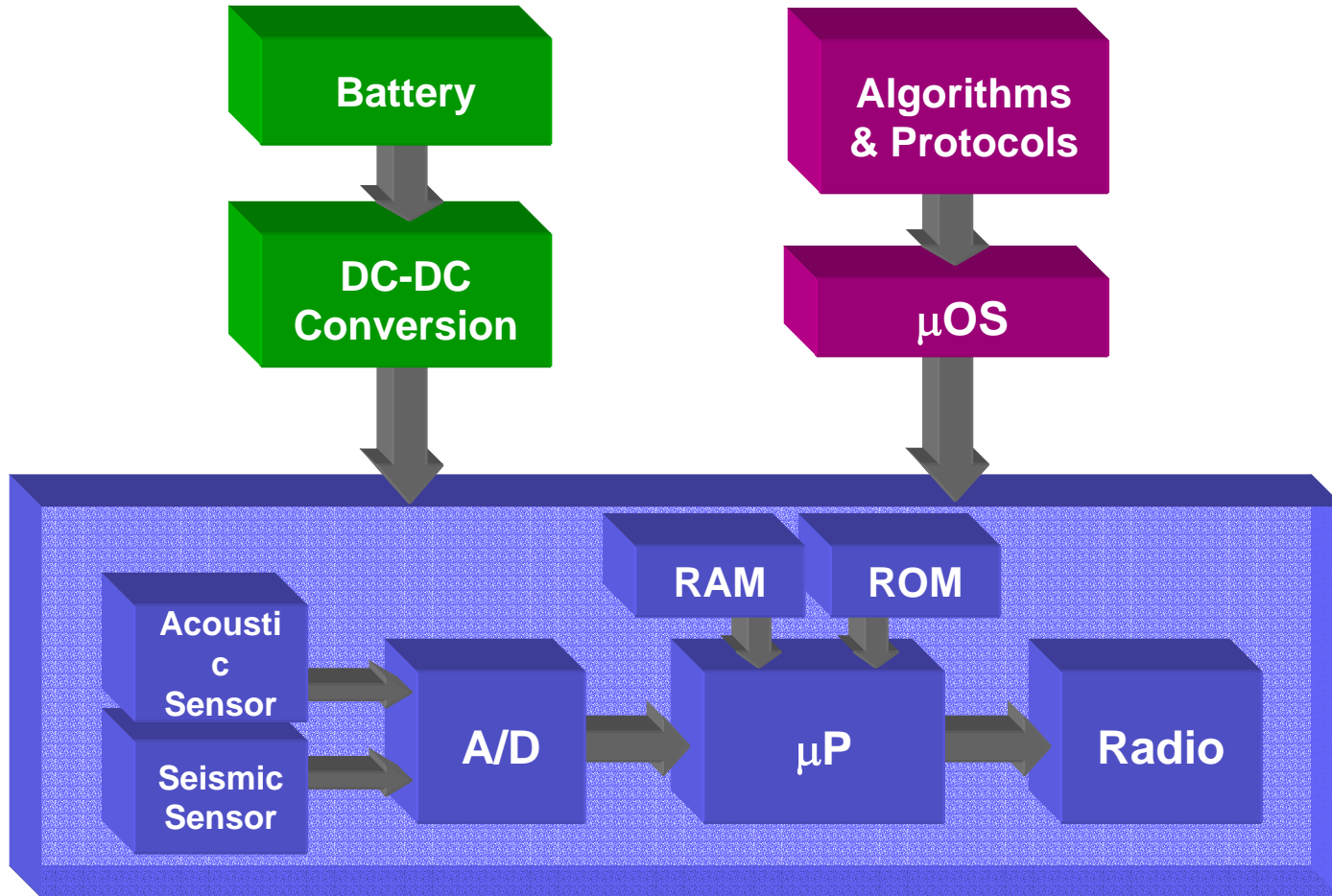



The μ AMPS Node



μ AMPS: micro-Adaptive Multi-Domain Power-Aware Sensors

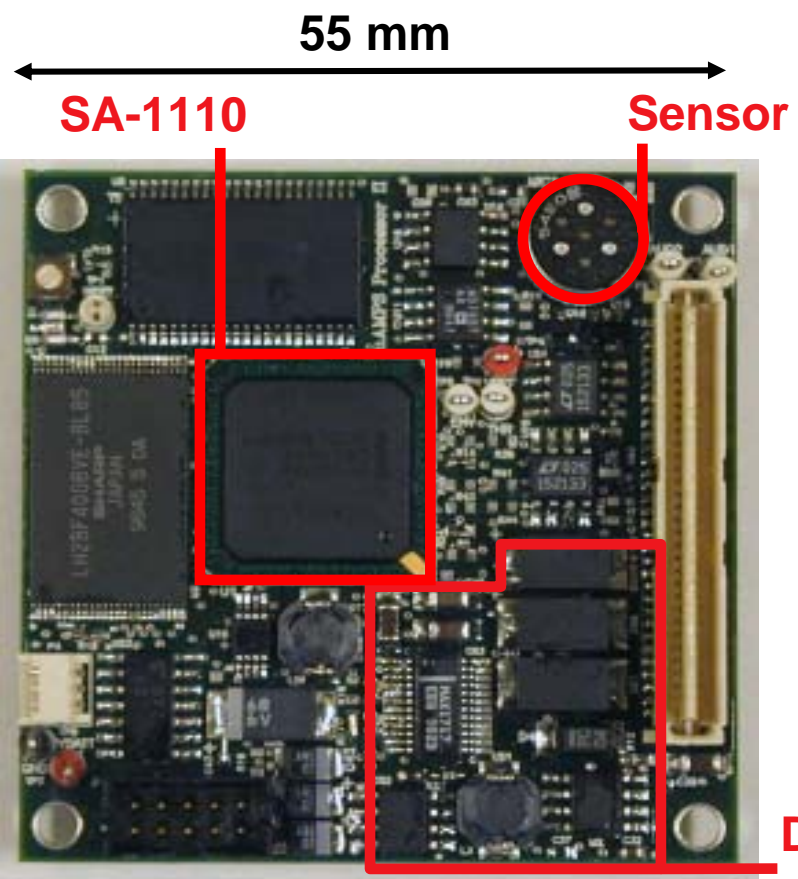

Processor Board

[Nathan Ickes]

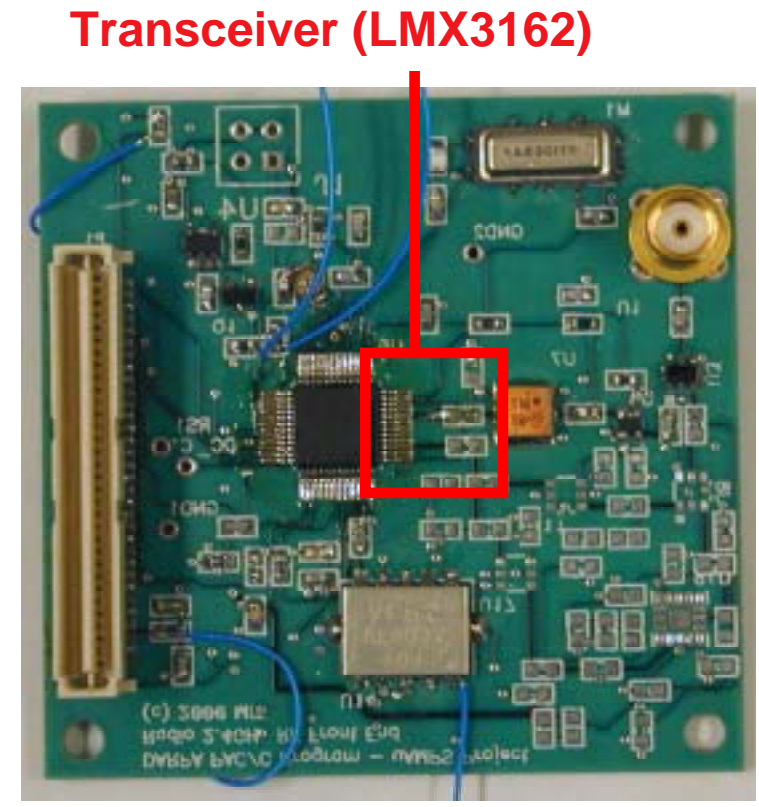

Radio

[Fred S. Lee, Theodore Konstantakopoulos]



Dynamic Voltage Scaling



- Hardware hooks:
 - Voltage
 - Frequency
- Using the hooks:
 - Application has deadline for computation
 - Exploit conservative deadline to save energy

$$\mathbf{Power = \alpha C V_{DD}^2 f}$$

$$\mathbf{Energy = \frac{1}{2} C V_{DD}^2}$$



Latency-Awareness



Time required for operation



$$E_{\text{FIXED}} = \frac{1}{2} C V_{\text{DD}}^2$$

$$E_{\text{VARIABLE}} = \frac{1}{2} C (V_{\text{DD}}/2)^2 = E_{\text{FIXED}} / 4$$

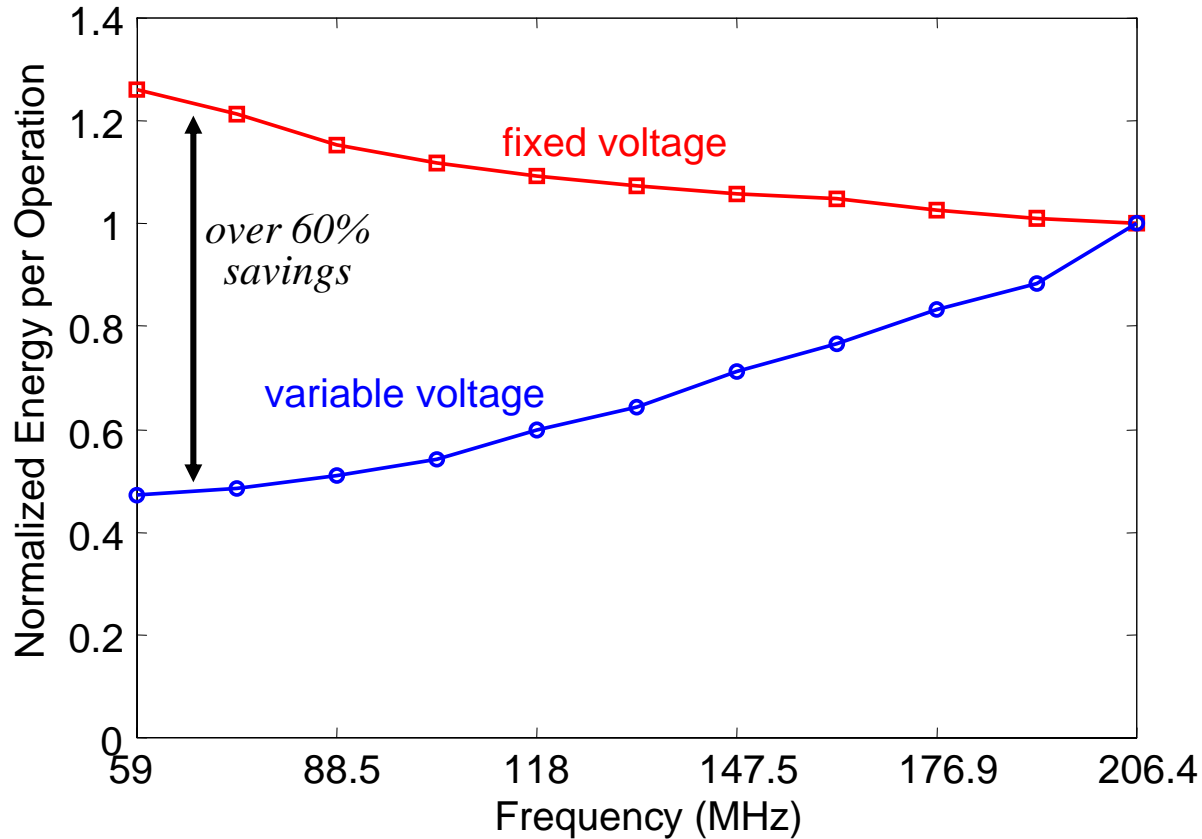



Leakage vs. Switching Energy

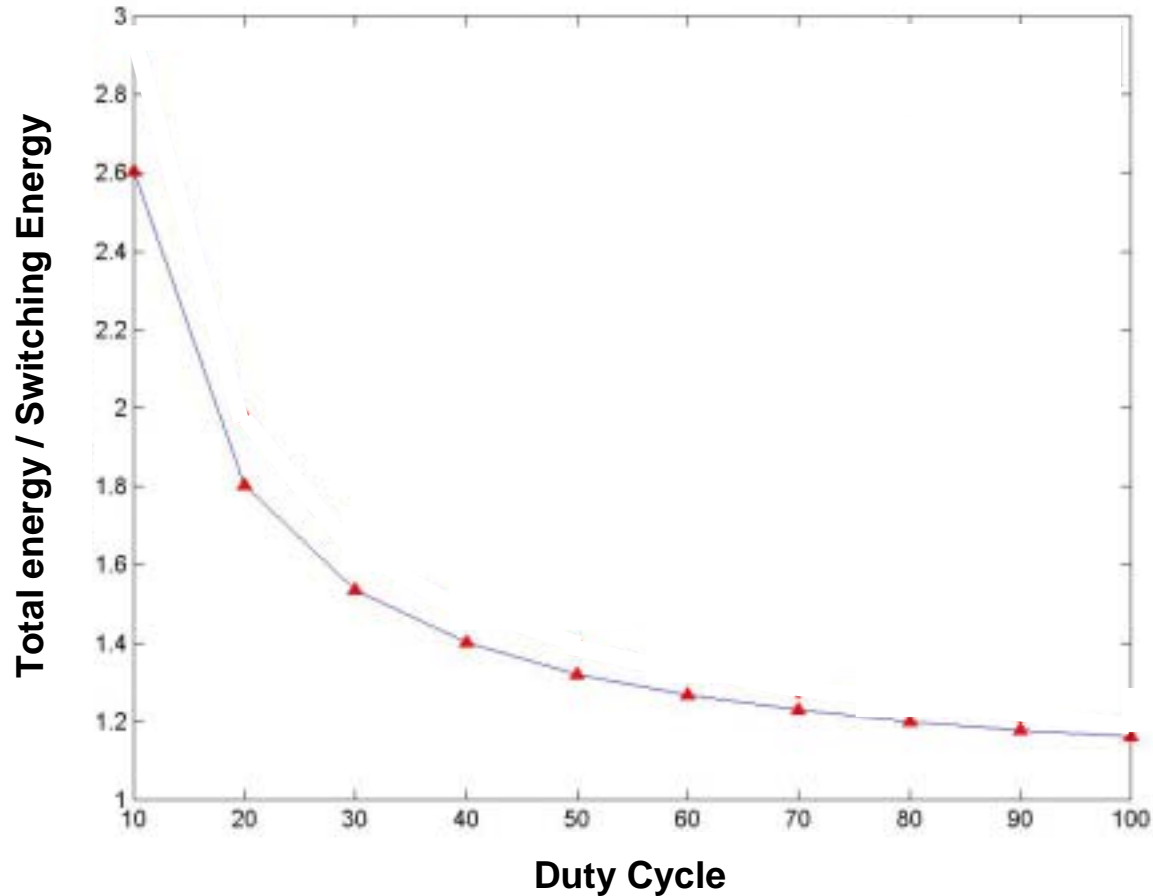

Leakage dominates switching energy at low duty cycles



Shutdown Modes on μ AMPS node

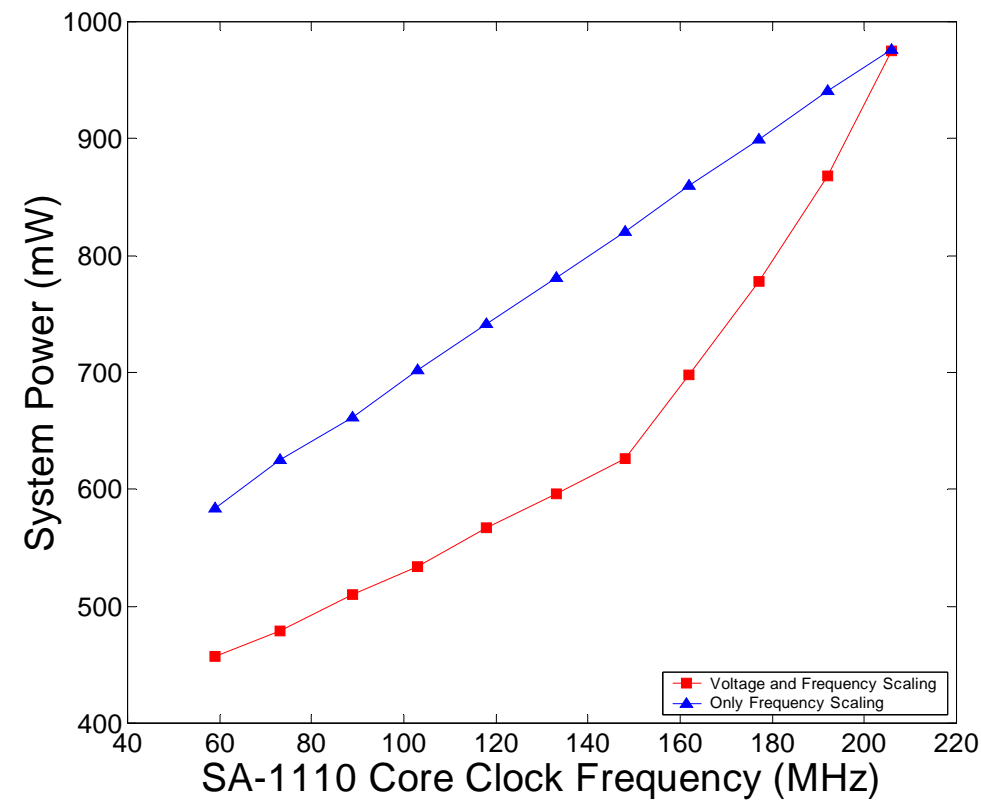
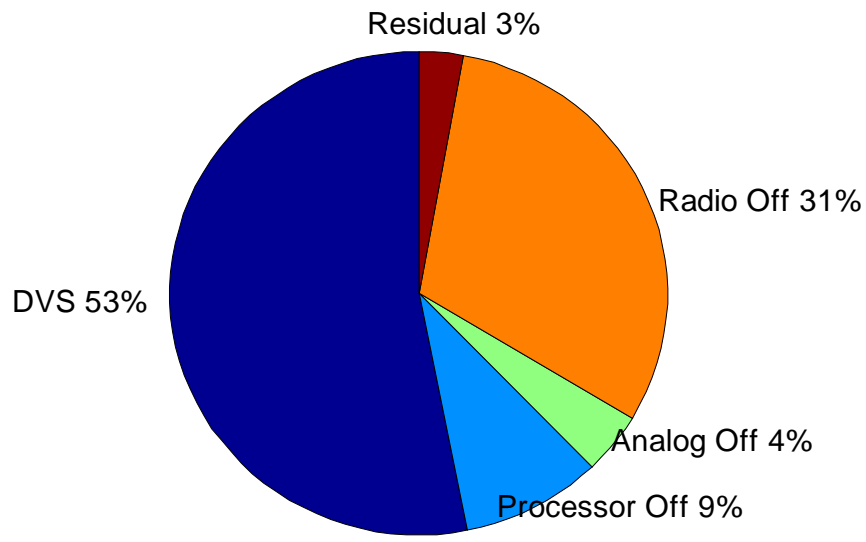

- Total power = 975.6 mW (Radio power approximated)
- Duty Cycle of 1% \rightarrow 27x lifetime improvement



Energy-Efficient Signal Processing

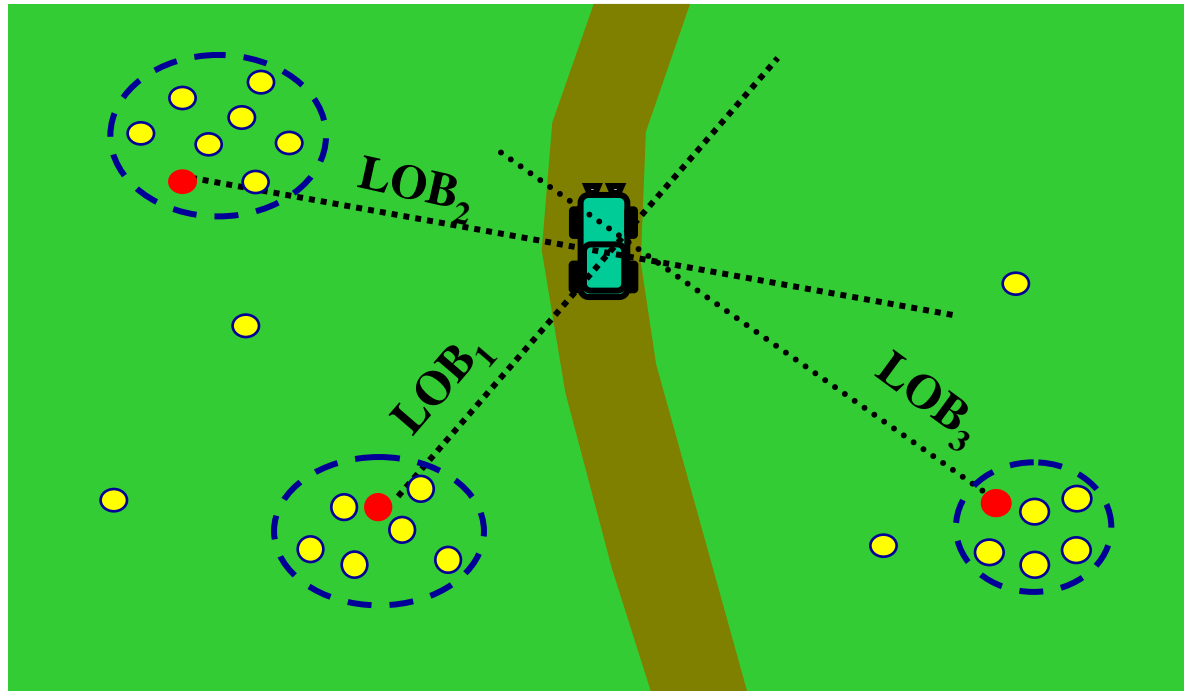

- Vehicle tracking application
 - Sensors used to form cluster
 - Multiple clusters used to estimate line of bearing (LOB)
 - Cluster sends data to remote user where tracking is performed
- Goal: Devise energy-efficient technique for LOB estimation and vehicle tracking



Line of Bearing Algorithm

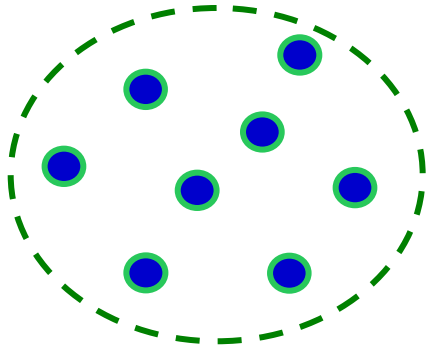

M sensor array

- LOB estimated by delay-and-sum beamforming algorithm
- Direction with strongest signal forms LOB estimate
- Algorithm performed in frequency domain

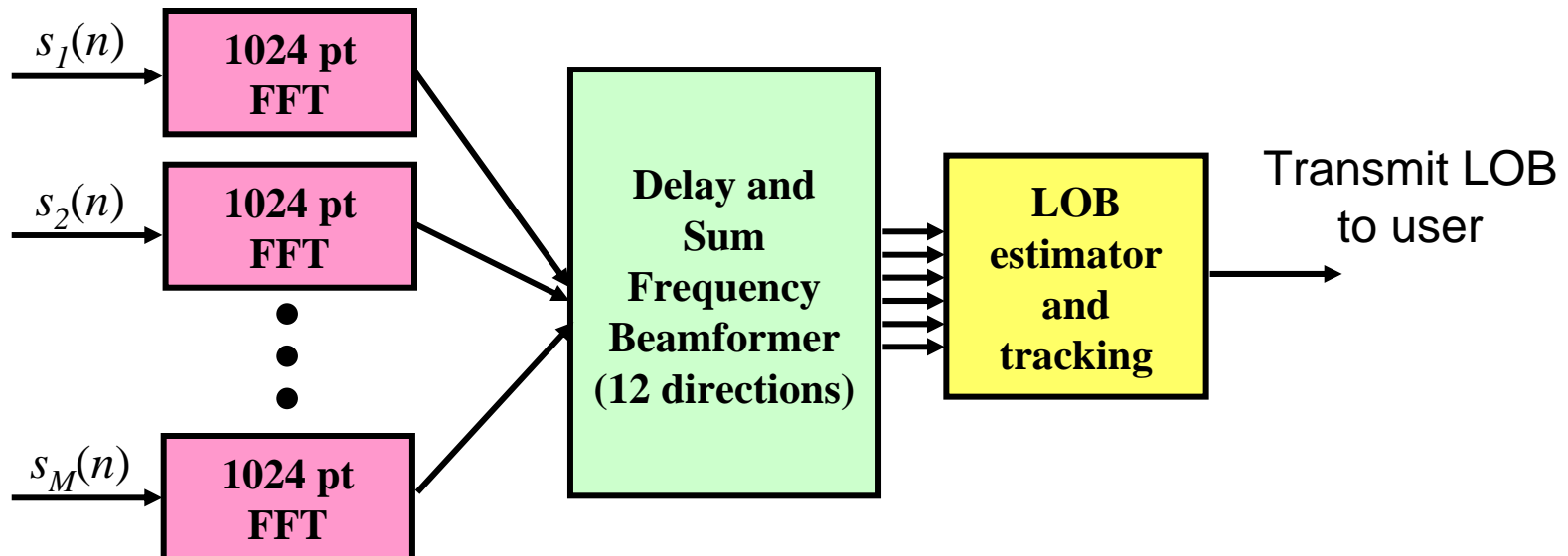

[Courtesy N. Srour (Army Research Laboratories)]

LOB Estimation: Direct Approach

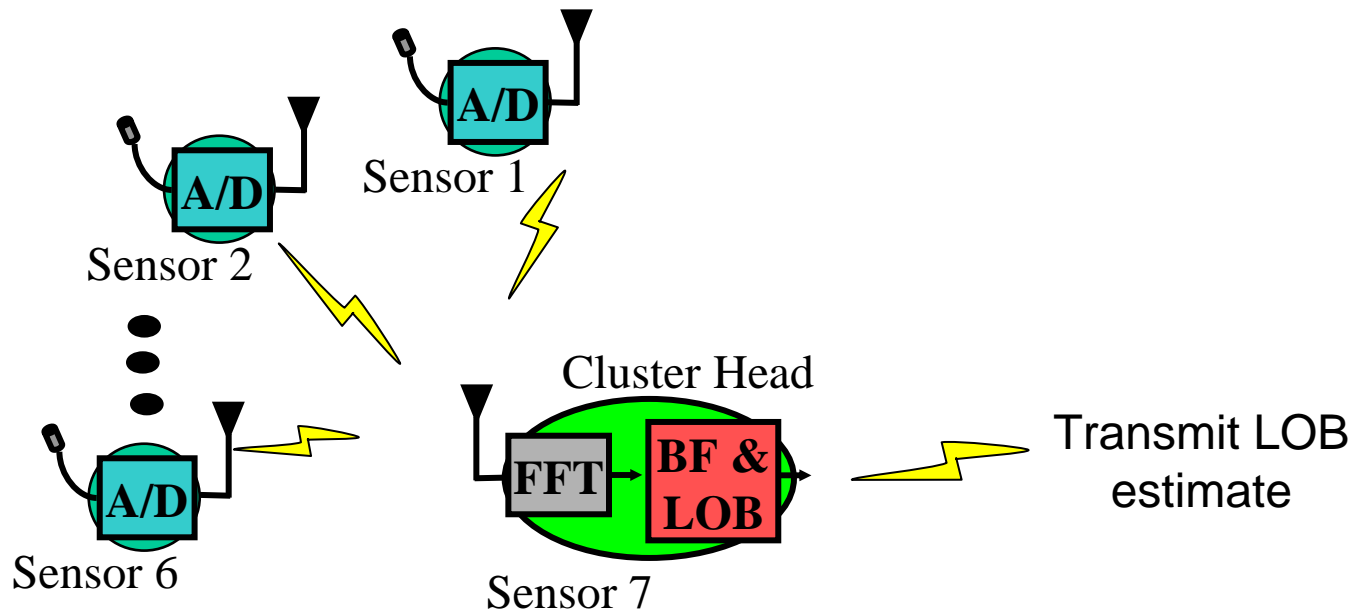

- Direct approach: LOB algorithm performed at the clusterhead and then estimate is sent to user

$$\begin{aligned} E_{comp}(V_{dd} = 1.44 \text{ V}) &= 7 * E_{fft} + E_{bf} + E_{LOB} \\ &= 6.01 \text{ mJ} \end{aligned}$$

$$Latency_{comp} = 19.2 \text{ ms}$$



Computation and Energy Partitioning



Queue
FFT(s₁)
FFT(s₂)

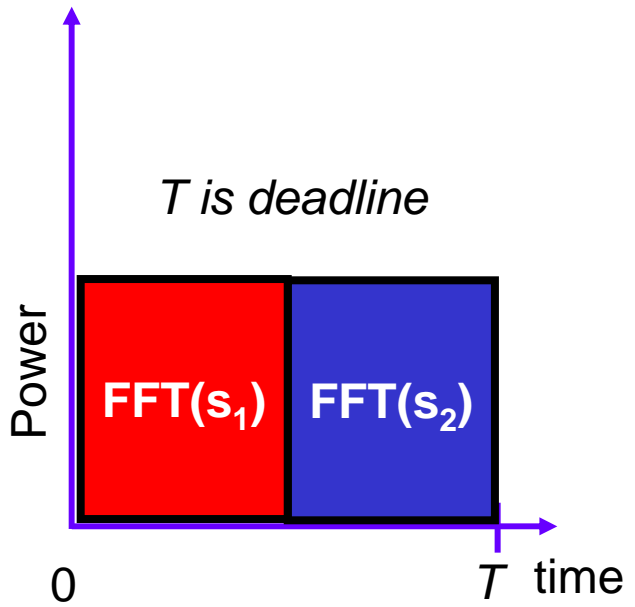
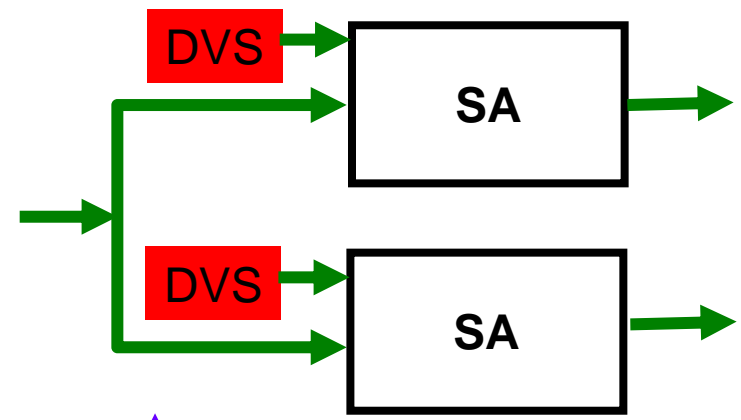

$$E_{fft} = 2 N_{fft} C V_{fft}^2$$

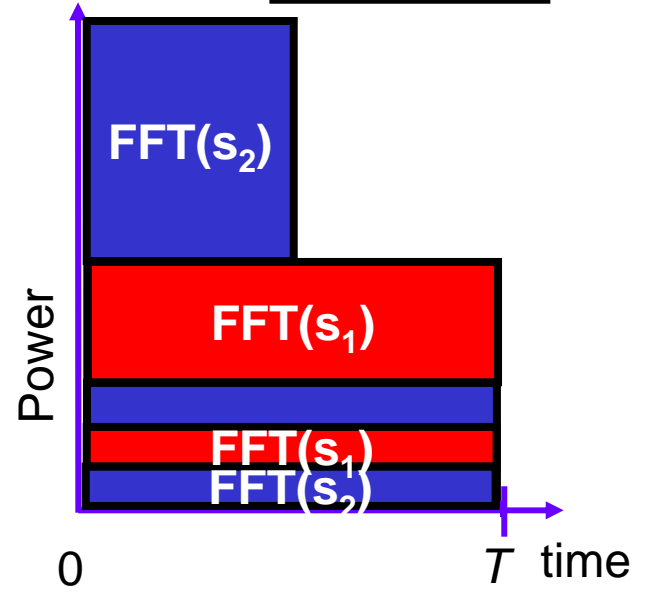

$$E_{fft} = 2 N_{fft} C (V_{fft}/2)^2$$

1/4 energy dissipated



Energy-Efficient LOB Estimation

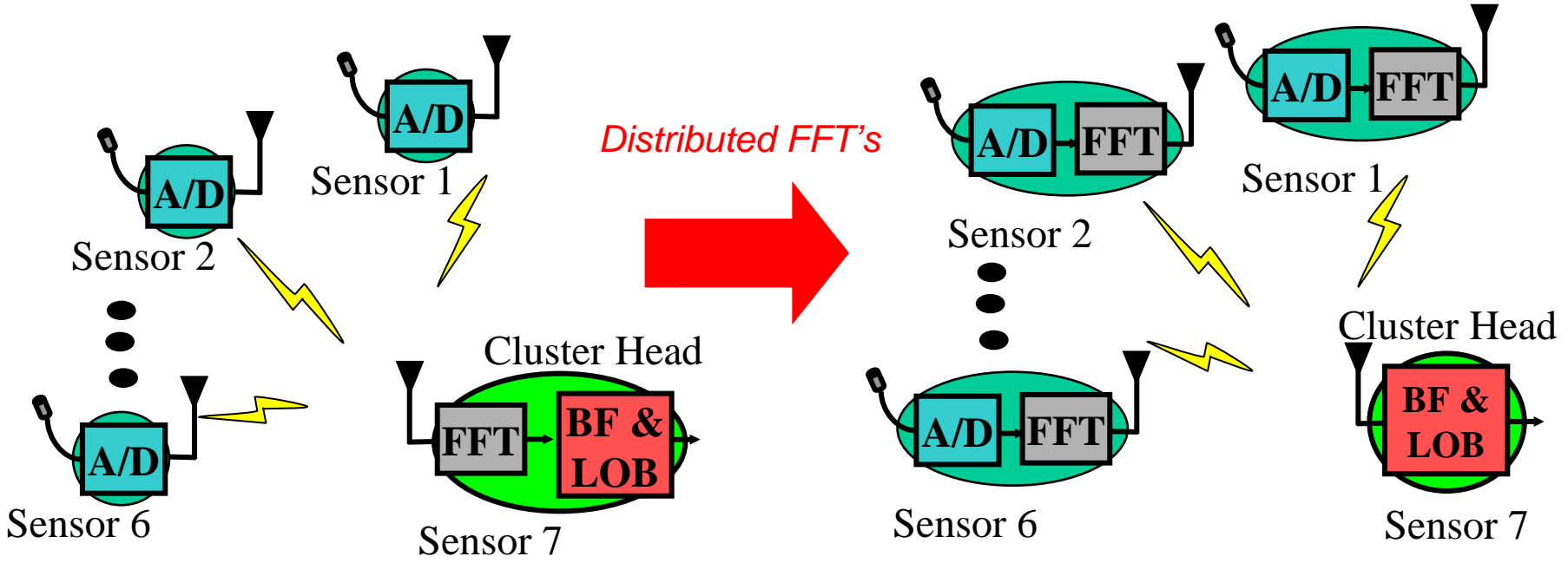

Latency	19.2 ms	18.4 ms
Energy	6.2 mJ	3.4 mJ



Power-Aware Communication

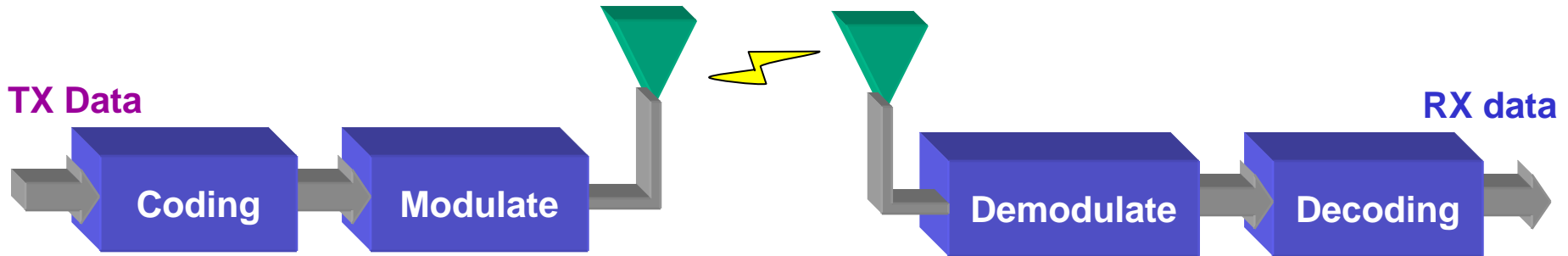

■ Assumptions

- Rayleigh fading with AWGN
- Probability of error is the desired parameter

■ Various techniques to meet requirement

- Increase transmit power
- Add forward error correction



Effect of Coding

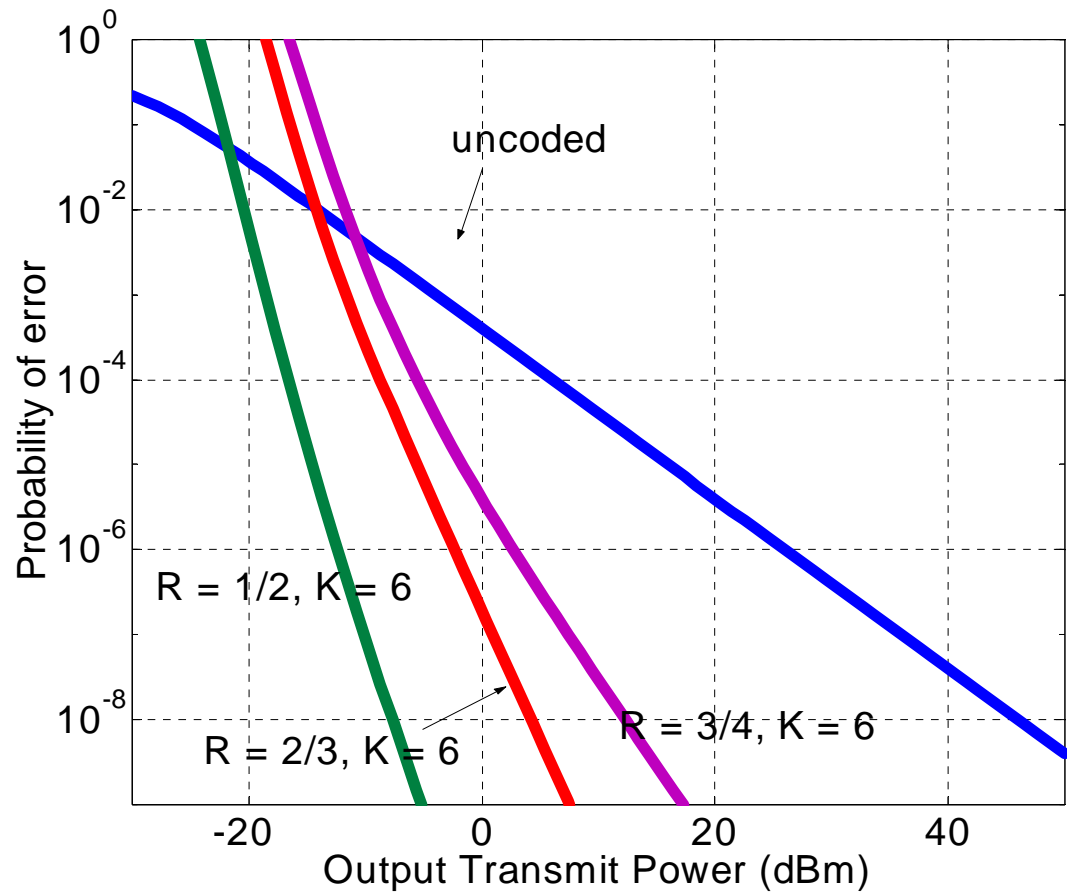

Communication View: Coding Always Good



Energy Cost of Communication

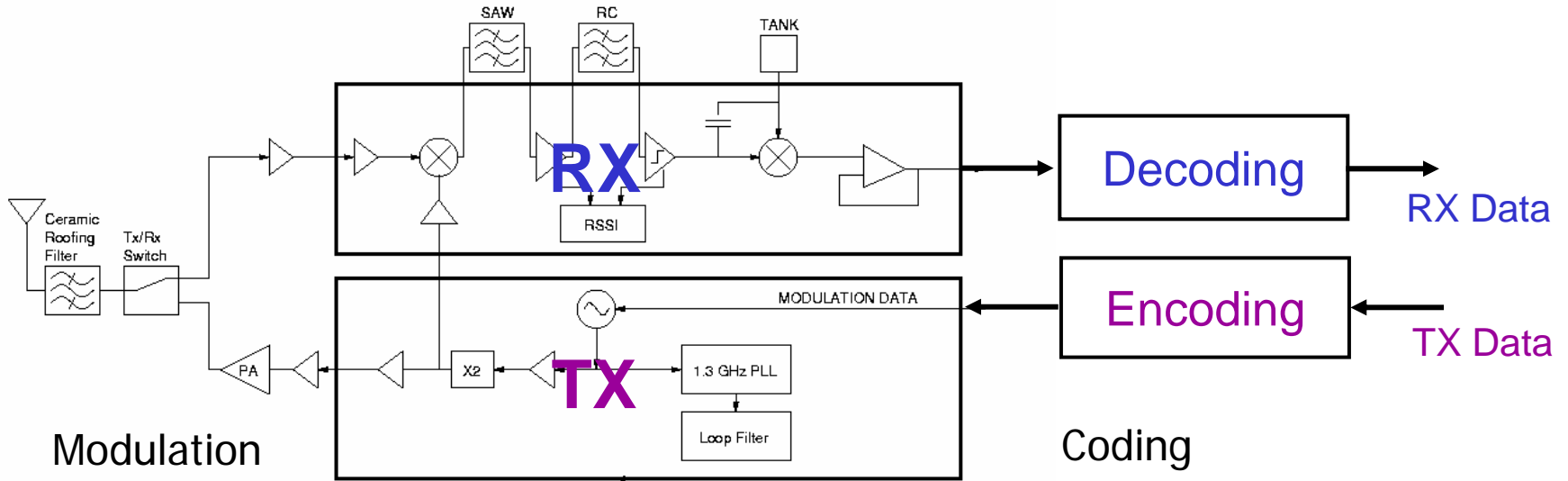

$$E_{radio} = E_{rx} + E_{tx}$$

$$E_{radio} = [P_{rx}(T_{on} + T_{startup})] + [P_{tx}(T_{on} + T_{startup}) + P_{out}(T_{on})]$$

$$E_{FEC} = E_{FEC}^{(e)} + E_{FEC}^{(d)}$$

Fixed Parameters

P_{tx}	81 mW
P_{rx}	180 mW
$T_{startup}$	466 μ s

Tunable Parameters

P_{out}
T_{on}
E_{FEC}



Wasted Energy: Startup Time



Startup time screen capture

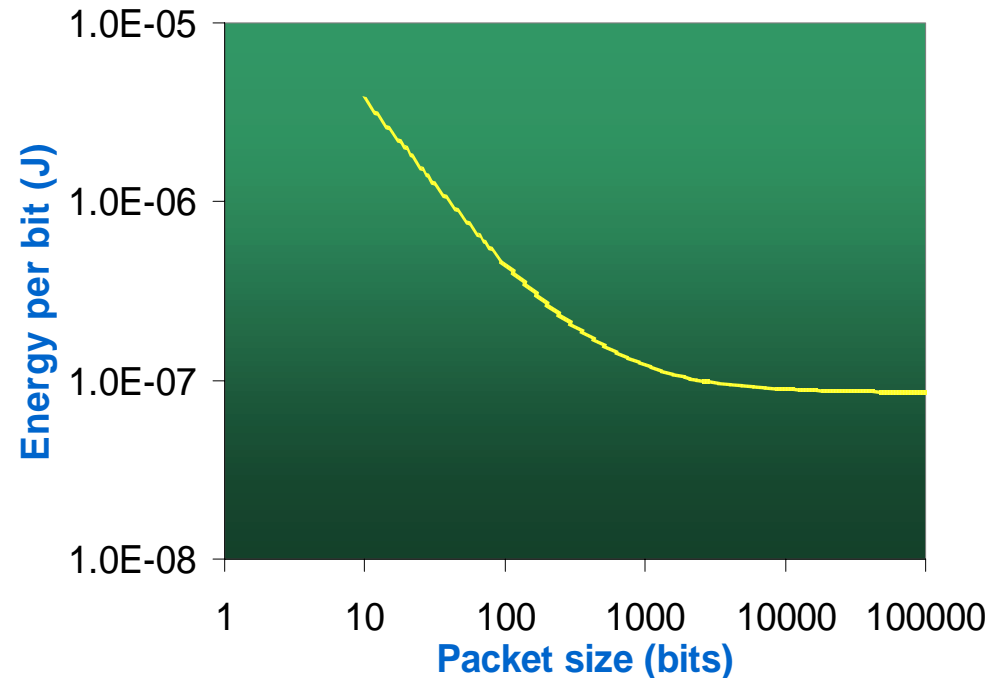
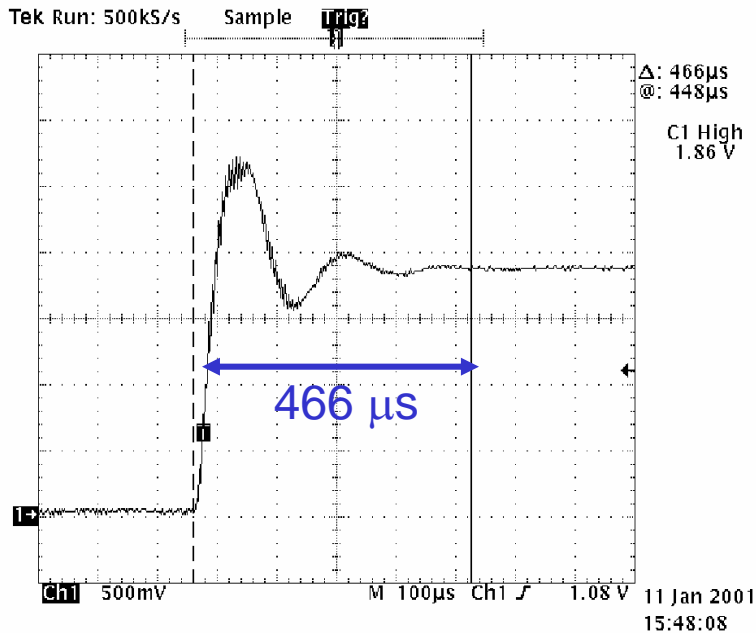

- Fixed cost of communication (startup time)
 - High energy per bit for small packet



Coding Energy: StrongARM



- Encoding energy negligible
- Decoder energy increases with constraint length
 - States proportional to 2^{K-1}

$R = 1/2, K = 3$	2200 nJ/bit
$R = 1/2, K = 6$	40000 nJ/bit

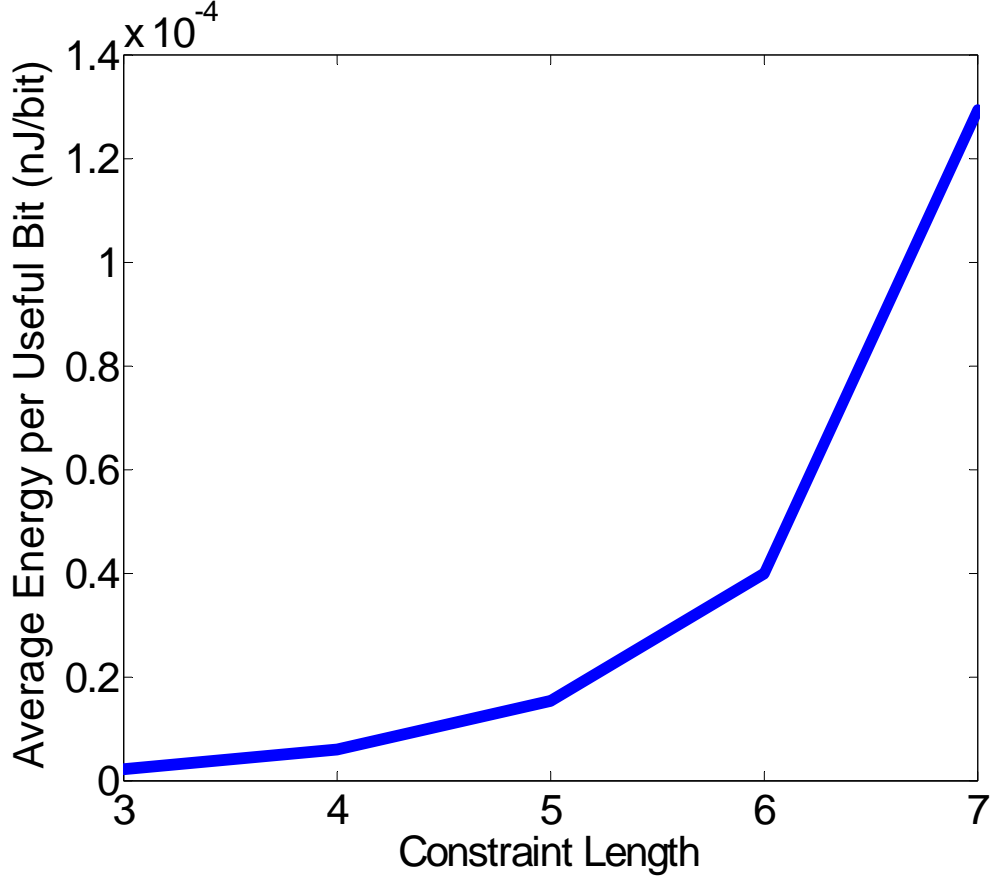



Coding Depends on BER



- Computation energy dominates at high BER
- Transceiver and power amplifier dominates at low BER
 - “Strongest” ECC most energy-efficient

Energy vs. Probability of Error

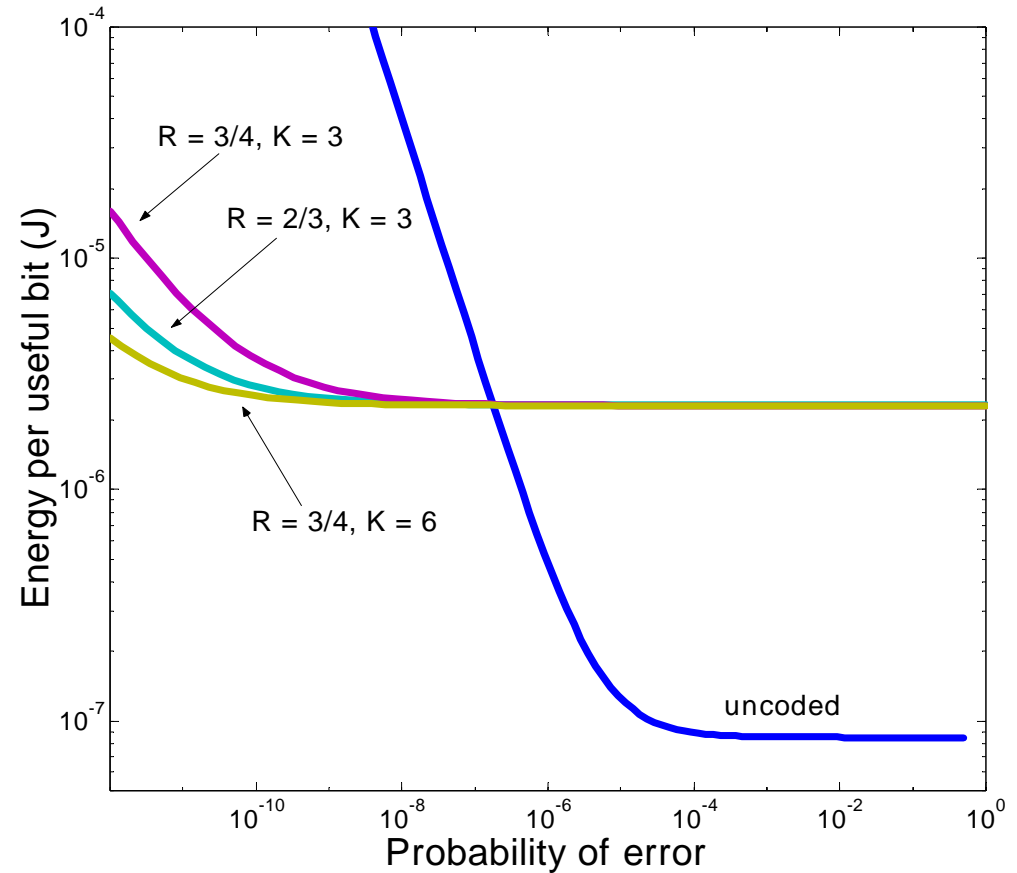



Computation Cost: StrongARM vs. ASIC

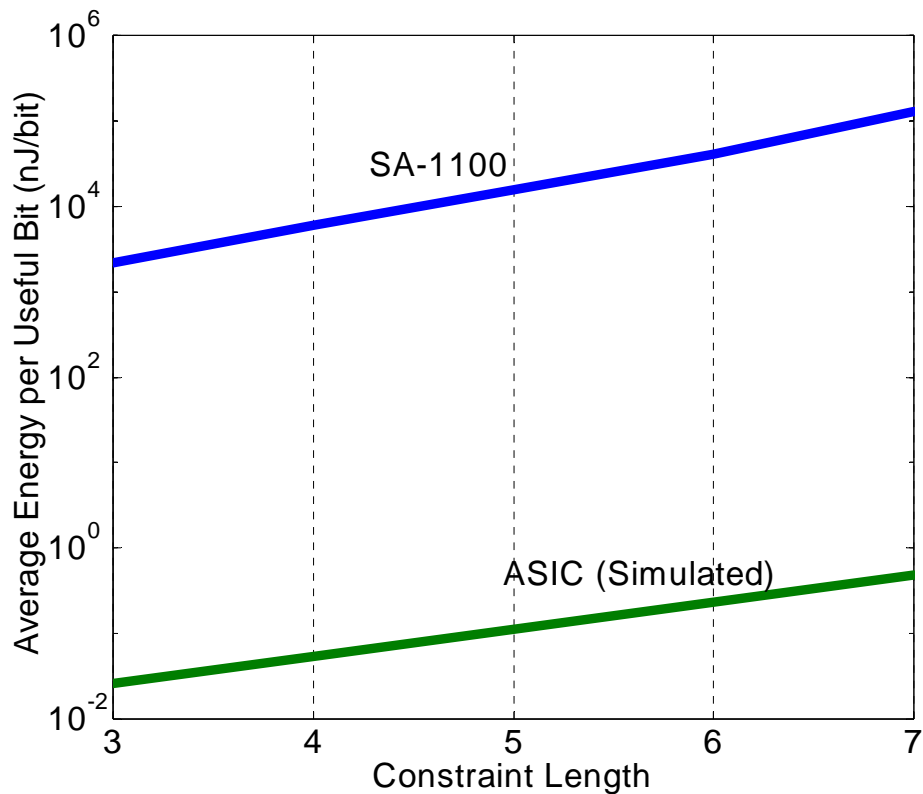

	R = 1/2 K = 3	R = 1/2 K = 6
ASIC (nJ/bit)	0.026	0.225
SA-1100 (nJ/bit)	2200	40000

- Viterbi decoder on StrongARM is inefficient
- Decoding energy is 5 orders less



Tradeoff Still Exists with ASIC



- Computation is cheaper, but coding does not always win
 - Transceiver energy dominant at high BER
- Reduce transceiver energy
 - Use higher rate code

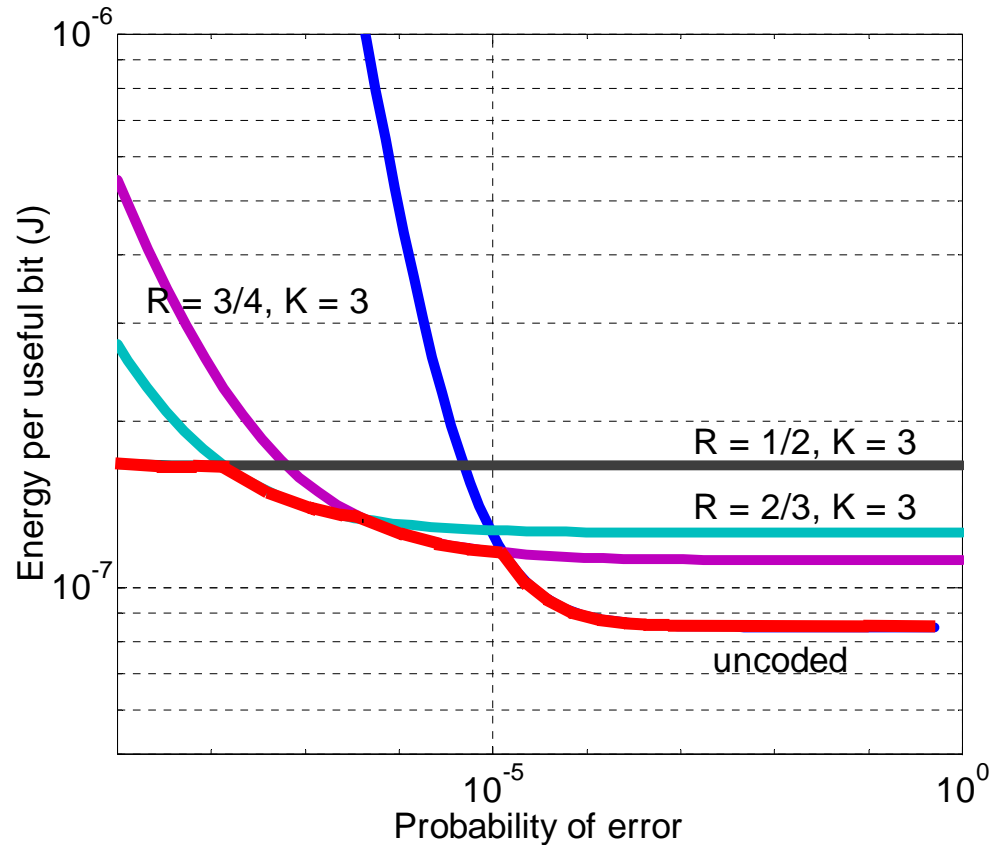

Coding Not Always Good



Total Communication Energy Savings



■ Scenario:

- ❑ Receiving node has 5 BER requirements
 - 10^{-3} to 10^{-7}
- ❑ Send 100 packets per BER requirement
- ❑ Adaptive strategy vs. non-adaptive strategies

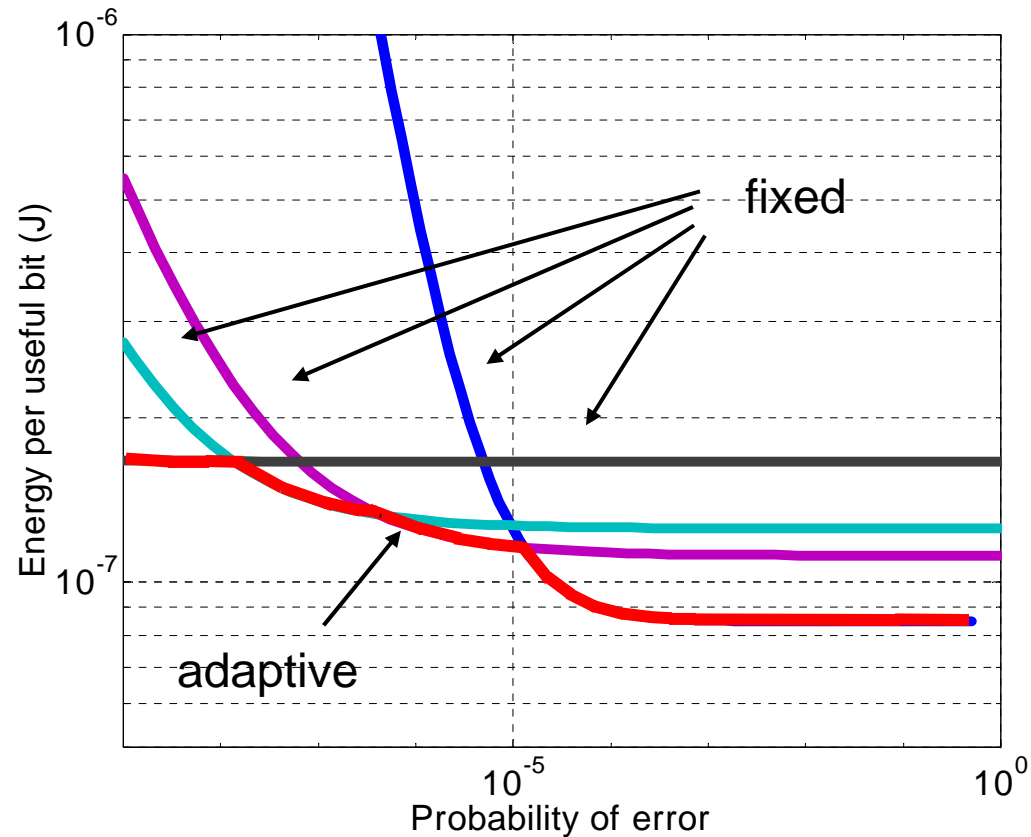



Total Communication Energy Savings



Strategy	Energy (J)
No coding	4.5
$R = \frac{1}{2}, K = 3$	0.83
$R = \frac{3}{4}, K = 3$	0.61
Variable	0.55

Table 1: Total energy consumed to transmit 500 packets while maintaining user requirements (10^{-3} to 10^{-7})

Adaptive Strategy vs. Fixed Scheme	Percentage Energy Saved by Adaptive Strategy (%)
$R = \frac{1}{2}, K = 3$	51
$R = \frac{3}{4}, K = 3$	11

Table 2: Energy savings of adaptive strategy over 3 different fixed strategies in scenario described



Conclusion



- Nodes energy-constrained in wireless sensor networks
- Power-aware design is critical to achieve long lifetimes required in such networks
 - Must pervade all system layers
- Enabling power-awareness:
 - Need hardware that can be adapted
 - Energy characterization absolutely necessary
 - Apply DVS, physical layer adaptation, etc.