

Design of an optimal controller for a discrete-time system subject to previewable demand

TOHRU KATAYAMA†§, TAKAHIRA OHKI‡, TOSHIO INOUE‡
and TOMOYUKI KATO†

This paper is concerned with a method of designing a type one servomechanism for a discrete-time system subject to a time-varying demand and an unmeasurable constant disturbance. It is assumed that the time-varying demand is previewable in the sense that some finite future as well as present and past values of the demands are available at each time. A controller with state feedback plus integral and preview actions is derived by applying a linear quadratic integral (LQI) technique due to Tomizuka and Rosenthal (1979). It is shown under the stabilizability and detectability conditions that the closed-loop system achieves a complete regulation in the presence of small perturbations in system parameters, eliminating the effect of disturbance. An example of power plant control is presented to show the flexibility of the design method and the effectiveness of the preview action for improving the transient responses of the closed-loop system.

1. Introduction

In many practical control systems designs, it is required that the outputs, or the controlled variables, track without steady-state error the demand signals in the presence of unmeasurable disturbances. For more than a decade there has been much interest in tracking or servo-mechanism problems for linear time-invariant multivariable systems (Davison 1972, Smith and Davison 1972, Young and Willems 1972, Bradshaw and Porter 1976, Furuta and Kamiya 1982). Furthermore, design problems of robust servomechanisms have been extensively studied by the state-space and frequency-domain approaches (Davison and Goldenberg 1975, Davison 1976, Francis and Wonham 1976, Ferreira 1976). An overview of the state of knowledge on the robust servomechanism problem is presented by Desoer and Wang (1980).

In most papers mentioned above, however, it is assumed that the desired signals as well as disturbances are constants, or ramp functions, or more generally the outputs of some free time-invariant linear systems. More recently, assuming that the disturbances are previewable, Tomizuka and Rosenthal (1979) have developed a digital controller with state feedback plus integral and preview actions for a discrete-time system with a constant demand input; they have shown that the preview of future disturbances is very effective for improving the transient responses of the closed-loop system. A related finite preview control problem for a continuous-time system is also considered by Tomizuka (1975).

This paper deals with a tracking problem for a discrete-time system in the presence

Received 3 April 1984.

† Department of Applied Mathematics and Physics, Faculty of Engineering, Kyoto University, Kyoto 606, Japan.

‡ Control System Design Department, Boiler Plant Division, Ishikawajima-Harima Heavy Industries Co. Ltd., Tokyo 135, Japan.

§ Present address: Department of Mechanical and Industrial Engineering, Faculty of Engineering, Ehime University, Matsuyama 790, Japan.

of unmeasurable disturbances. It is assumed that the demand signal is rather arbitrary but eventually converges to a constant vector, and that finite future values of the demand signal are available at each instant of time. These assumptions may not be unrealistic in many practical control problems. For example, in power plant control, the outputs must be kept at constant levels over a period of time, where the constant levels, or the set points, may change from time to time according to the load demand, for which a local future information is available. We wish to present a method of designing an optimal type one servomechanism for a discrete-time system by extending the linear quadratic integral (LQI) technique due to Tomizuka and Rosenthal (1979).

This paper is organized as follows. In § 2, we formulate the tracking problem as an LQI problem by defining an appropriate performance index and an augmented state-space model that includes the available future demands as a part of the state vector. The optimal controller with state feedback plus integral and preview actions is derived in § 3. Section 4 presents some preliminary lemmas. In § 5, we show that the closed-loop system is asymptotically stable and hence a complete regulation occurs under the conditions of stabilizability (or reachability) and detectability (or observability). We also show that a complete regulation occurs in the presence of small perturbations in system parameters. Section 6 is devoted to the stability analysis of the overall system when an observer is incorporated into the state feedback loop. A numerical example taken from a power plant control is provided in § 7 to show the feasibility of the present method and the effectiveness of the preview action for improving the transient responses of the plant.

2. Problem statement

We consider a time-invariant linear discrete system described by

$$x(k+1) = Ax(k) + Bu(k) + Ew(k) \quad (1)$$

$$y(k) = Cx(k) \quad (2)$$

where $x(k)$ is the $n \times 1$ state vector, $u(k)$ the $r \times 1$ control vector, $y(k)$ the $p \times 1$ output vector to be controlled and $w(k)$ the $q \times 1$ inaccessible constant disturbance. A , B , C and E are constant matrices of dimensions $n \times n$, $n \times r$, $p \times n$ and $n \times q$, respectively. It is assumed that $\text{rank } B = r$, $\text{rank } C = p$ and $\text{rank } E = q$.

Let $y_d(k)$ be the $p \times 1$ desired output, or the demand vector, for which we assume that there exists a constant vector \bar{y}_d such that

$$\lim_{k \rightarrow \infty} y_d(k) = \bar{y}_d$$

This implies that the demand vector is an arbitrary time-varying function, except that it reaches a steady state. We further assume that the demand is previewable in the sense that at each time k , N_L future values $y_d(k+1), \dots, y_d(k+N_L)$ as well as the present and past values of the demand are available. The future values of the desired output beyond time $k+N_L$ are approximated by $y_d(k+N_L)$, namely

$$y_d(k+i) = y_d(k+N_L), \quad i = N_L + 1, \dots \quad (3)$$

The basic design problem considered in this paper is to find a controller such that:

- (i) In the steady state, the output $y(k)$ tracks the demand vector $y_d(k)$ in the presence of disturbance $w(k)$.

(ii) The control vector $u(k)$ is bounded.

In order to eliminate the steady-state error, one servomechanism is used. When a disturbance occurs, $e(k)$ is the error signal. To design a controller, Tomizuka et al. (1972, Tomizuka and Rosenthal 1979) proposed the integral action. Let the control vector $u(k)$ be the integral action of the error signal. The performance index J is defined as

is minimized. The matrix Q is positive definite and R is positive semi-definite. \bar{y}_d denotes the desired output. It should be noted that the error signal $e(k)$ is the difference between the output $y(k)$ and the desired output $y_d(k)$. The increment of J is the sum of the squares of the state and control vectors, which is more flexible than the other variables.

3. Design

We derive the optimal control law on the basis of the preview action and the integral action.

where we assume that the disturbance $w(k)$ satisfies

where the matrix A is

Combining the preview action and the integral action, the control vector $u(k)$ is

where $i = 0, 1, \dots$

- (ii) The closed-loop system is asymptotically stable and exhibits acceptable transient responses.

In order to meet the above requirements, it is desired to introduce integrators to eliminate the tracking error $e(k) = y(k) - y_d(k)$. In other words, we must design a type one servomechanism for the system of (1) and (2) such that the asymptotic regulation occurs, $e(k) \rightarrow 0$ as $k \rightarrow \infty$, while keeping the transient responses satisfactory in some sense. To this end, we employ the LQI technique (Athans 1971, Smith and Davison 1972, Tomizuka and Rosenthal 1979).

Let the incremental state vector be $\Delta x(k) = x(k) - x(k-1)$ and let the incremental control vector be $\Delta u(k) = u(k) - u(k-1)$. It is well known (Athans 1971) that the integral action of the controller is introduced by including the incremental control in the performance index. Therefore we wish to obtain the optimal controller $u(k)$ such that the performance index

$$J = \sum_{i=k}^{\infty} [e^T(i)Q_e e(i) + \Delta x^T(i)Q_x \Delta x(i) + \Delta u^T(i)R \Delta u(i)] \quad (4)$$

is minimized at each time k , where Q_e and R are $p \times p$ and $r \times r$ symmetric positive definite matrices respectively, Q_x is an $n \times n$ symmetric non-negative definite matrix, i denotes the dummy time index and the superscript $(\cdot)^T$ denotes the transpose.

It should be noted that the term $e^T(i)Q_e e(i)$ represents the loss due to tracking error, and that $\Delta x^T(i)Q_x \Delta x(i)$ and $\Delta u^T(i)R \Delta u(i)$ represent the losses due to the incremental state and control vectors respectively. Thus the physical interpretation of J is to achieve the asymptotic regulation without excessive rate of change in the state and control vectors. The quadratic term for the rate of change in state vector, which is not used in Tomizuka and Rosenthal (1979), will make the design technique more flexible allowing us to directly regulate the transient responses of the state variables.

3. Design of optimal controller

We derive an augmented state-space description that includes the future information on the demand signal as well as the error $e(i)$, the incremental state vector $\Delta x(i)$ and the incremental control vector $\Delta u(i)$. From (1), the incremental state is described by

$$\Delta x(i+1) = A \Delta x(i) + B \Delta u(i), \quad i = k, k+1, \dots \quad (5)$$

where we note that the incremental disturbance $\Delta w(k)$ does not appear because the disturbance is a step function. Also, we see from (2) and (5) that the tracking error satisfies

$$e(i+1) = e(i) + CA \Delta x(i) + CB \Delta u(i) - \Delta y_d(i+1), \quad i = k, k+1, \dots \quad (6)$$

where the incremental demand is defined by

$$\Delta y_d(i) = y_d(i) - y_d(i-1) \quad (7)$$

Combining (5) and (6) yields

$$\begin{bmatrix} e(i+1) \\ \Delta x(i+1) \end{bmatrix} = \begin{bmatrix} I_p & CA \\ 0 & A \end{bmatrix} \begin{bmatrix} e(i) \\ \Delta x(i) \end{bmatrix} + \begin{bmatrix} CB \\ B \end{bmatrix} \Delta u(i) + \begin{bmatrix} -I_p \\ 0 \end{bmatrix} \Delta y_d(i+1) \quad (8)$$

where $i = k, k+1, \dots$, and I_p denotes the $p \times p$ unit matrix.

Since N_L future demands $y_d(i)$, $i = k + 1, \dots, k + N_L$, are available at time k , the relevant information on the incremental demand can be summarized as the $pN_L \times 1$ vector

$$x_d(k) = [\Delta y_d^T(k + 1), \dots, \Delta y_d^T(k + N_L)]^T \tag{9}$$

It follows from the assumption of (3) that $x_d(i)$ satisfies

$$x_d(i + 1) = A_d x_d(i), \quad i = k, k + 1, \dots \tag{10}$$

where

$$A_d = \begin{bmatrix} 0 & I_p & \mathbf{0} \\ & 0 & \ddots \\ & & \ddots & I_p \\ \mathbf{0} & & & 0 \end{bmatrix}_{(pN_L \times pN_L)} \tag{11}$$

Now define the $(p + n + pN_L) \times 1$ augmented state vector

$$\bar{x}(i) = [e^T(i) \quad \Delta x^T(i) \quad x_d^T(i)]^T \tag{12}$$

Putting (8) and (10) together yields

$$\bar{x}(i + 1) = \begin{bmatrix} I_p & CA & \vdots & -I_p & 0 & \dots & 0 \\ 0 & A & \vdots & 0 & 0 & \dots & 0 \\ \dots & \dots & \dots & \dots & \dots & \dots & \dots \\ 0 & & \vdots & & A_d & & \end{bmatrix} \bar{x}(i) + \begin{bmatrix} CB \\ B \\ \dots \\ 0 \end{bmatrix} \Delta u(i), \quad i = k, k + 1, \dots \tag{13}$$

On the other hand, in terms of the augmented state vector $\bar{x}(i)$, the performance index J of (4) is expressed as

$$J = \sum_{i=k}^{\infty} \left\{ \bar{x}^T(i) \begin{bmatrix} Q_e & 0 & 0 \\ 0 & Q_x & 0 \\ 0 & 0 & 0 \end{bmatrix} \bar{x}(i) + \Delta u^T(i) R \Delta u(i) \right\} \tag{14}$$

Therefore, the optimal controller can be derived by solving the optimal control problem that minimizes the performance index J of (14) subject to the dynamic constraint of (13).

For the sake of simplicity, we define

$$\tilde{B} = \begin{bmatrix} CB \\ B \end{bmatrix}, \quad \tilde{I} = \begin{bmatrix} I_p \\ 0 \end{bmatrix}, \quad \tilde{F} = \begin{bmatrix} CA \\ A \end{bmatrix}, \quad \tilde{Q} = \begin{bmatrix} Q_e & 0 \\ 0 & Q_x \end{bmatrix}, \quad \tilde{A} = [\tilde{I} \quad \tilde{F}] \tag{15}$$

Theorem 1

The optimal incremental control $\Delta u^o(k)$ is given by

$$\Delta u^o(k) = -G_I e(k) - G_x \Delta x(k) - \sum_{l=1}^{N_L} G_d(l) \Delta y_d(k + l) \tag{16}$$

where

$$G_I = [R + \tilde{B}^T \tilde{K} \tilde{B}]^{-1} \tilde{B}^T \tilde{K} \tilde{I} \tag{17 a}$$

$$G_x = [R + \tilde{B}^T \tilde{K} \tilde{B}]^{-1} \tilde{B}^T \tilde{K} \tilde{F} \tag{17 b}$$

and wher algebraic

Furtherm

where \tilde{A}_c

Proof

A pro

Theorem

The o

where it i

Proof

A pro

It shou the first to represents based on

We ot $u^o(k)$ beco

Moreover

This is a s Let $v(k)$

or

at time k ,
and as the

$$G_d(1) = -G_I \tag{17 c}$$

$$G_d(l) = [R + \tilde{B}^T \tilde{K} \tilde{B}]^{-1} \tilde{B}^T \tilde{X}(l-1), \quad l = 2, \dots, N_L \tag{17 d}$$

(9)

and where the $(p+n) \times (p+n)$ matrix \tilde{K} is the non-negative definite solution of the algebraic Riccati equation

$$\tilde{K} = \tilde{A}^T \tilde{K} \tilde{A} - \tilde{A}^T \tilde{K} \tilde{B} [R + \tilde{B}^T \tilde{K} \tilde{B}]^{-1} \tilde{B}^T \tilde{K} \tilde{A} + \tilde{Q} \tag{18}$$

(10)

Furthermore, the $(p+n) \times p$ matrices $\tilde{X}(l)$ are given by

$$\tilde{X}(l) = \tilde{A}_c^T \tilde{X}(l-1), \quad l = 2, \dots, N_L; \quad \tilde{X}(1) = -\tilde{A}_c^T \tilde{K} \tilde{I} \tag{19}$$

where \tilde{A}_c is the closed-loop matrix defined by

(11)

$$\tilde{A}_c = \tilde{A} - \tilde{B} [R + \tilde{B}^T \tilde{K} \tilde{B}]^{-1} \tilde{B}^T \tilde{K} \tilde{A} \tag{20}$$

Proof

A proof is elementary, and is given in Appendix A for completeness. □

(12)

Theorem 2

The optimal controller $u^o(k)$ is given by

$$u^o(k) = -G_I \sum_{i=0}^k e(i) - G_x x(k) - \sum_{i=1}^{N_L} G_d(i) y_d(k+i) \tag{21}$$

1, ... (13)

where it is assumed that $y(k) = y_d(k) = 0$, $x(k) = 0$ for $k = 0, -1, \dots$

Proof

A proof is immediate from Theorem 1. □

(14)

It should be noted that the optimal controller $u^o(k)$ of (21) consists of three terms; the first term represents the integral action on the tracking error, the second term represents the state feedback and the third term is the feedforward or preview action based on the local future information on the demand vector.

We observe that if $N_L = 0$, then the preview action disappears from (21) so that $u^o(k)$ becomes

$$u^o(k) = -G_I \sum_{i=0}^k e(i) - G_x x(k) \tag{22}$$

(15)

Moreover, since $G_d(1) = -G_I$ if $N_L = 1$, then we have

$$u^o(k) = -G_I \sum_{i=0}^k e(i) - G_x x(k) - G_d(1) y_d(k+1) \tag{23 a}$$

$$= -G_I \sum_{i=0}^k [y(i) - y_d(i+1)] - G_x x(k) \tag{23 b}$$

(16)

This is a state feedback controller with integral and feedforward actions.

Let $v(k)$ be the discrete integral of tracking error $e(k)$, namely

$$v(k) = v(k-1) + e(k) \tag{24}$$

(17 a)

or

(17 b)

$$v(k) = \frac{z}{z-1} e(k) \tag{25}$$

Thus it follows from (21) and (24) that the optimal controller is expressed as

$$u^o(k) = -G_I v(k) - G_x x(k) - \sum_{l=1}^{N_L} G_d(l) y_d(k+l) \tag{26}$$

Hence the resulting configuration of the overall system becomes as shown in Fig. 1. Noting that $e(k) = y(k) - y_d(k)$, it follows from (1), (2) and (24) that

$$v(k+1) = v(k) + CAx(k) + CBu(k) + CEw(k) - y_d(k+1) \tag{27}$$

Combining (1) and (27) gives

$$\begin{bmatrix} v(k+1) \\ x(k+1) \end{bmatrix} = \tilde{A} \begin{bmatrix} v(k) \\ x(k) \end{bmatrix} + \tilde{B}u(k) + \tilde{E}w(k) - \tilde{I}y_d(k+1) \tag{28}$$

where

$$\tilde{E} = \begin{bmatrix} CE \\ E \end{bmatrix} \tag{29}$$

Substituting (26) into (28) yields

$$\begin{bmatrix} v(k+1) \\ x(k+1) \end{bmatrix} = \tilde{A}_c \begin{bmatrix} v(k) \\ x(k) \end{bmatrix} - \tilde{B} \sum_{l=1}^{N_L} G_d(l) y_d(k+l) - \tilde{I}y_d(k+1) + \tilde{E}w(k) \tag{30}$$

where \tilde{A}_c is given by (20).

Therefore we observe that the closed-loop characteristic is determined by \tilde{A}_c , or the state feedback and the integral action, so that the stability of the overall system is independent of the preview action. It should be noted that the controller $u^o(k)$ is independent of the matrix E ; thus the exact knowledge of the disturbance matrix is not necessary for designing the optimal controller. Note that this is not the case if the state vector is not directly accessible (see § 6).

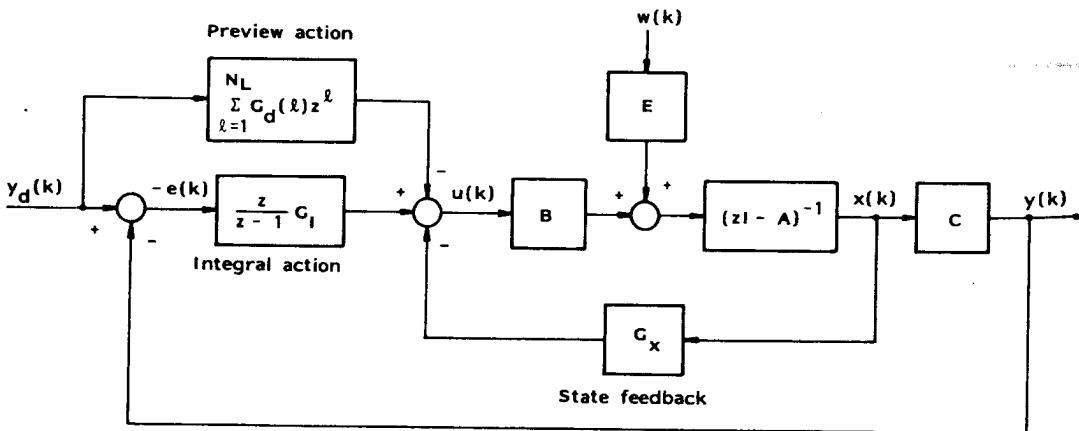

Figure 1. Overall configuration of feedback system.

4. Preliminary lemmas

In order to prove the asymptotic stability of the closed-loop system we need some preliminary lemmas for stabilizability (or reachability) and detectability (or observability).

Lemma 1:
The p
rank con

Proof
For th
employe
of (\tilde{A} , \tilde{B})

Since rar
 $\lambda \neq 1$. F

Thus we
Now
 $|\lambda| \geq 1$.
 $|\lambda| \geq 1$, w
(32) and

A con
(1972) by
condition
(Davison

Lemma 11
The p:
of (31) ho

Proof
For th
plex λ .
[$A - \lambda I_n$]
holds. N
reachable
 λ . Henc
complex

By ma
and Your
continuo

ed as

(26)

s shown in
at

(27)

(28)

(29)

k) (30)

ed by \tilde{A}_c , or
all system is
oller $u^o(k)$ is
matrix is not
ie case if the

Lemma 1a

The pair (\tilde{A}, \tilde{B}) is stabilizable if and only if (A, B) is stabilizable and the following rank condition holds

$$\text{rank} \begin{bmatrix} 0 & C \\ B & A - I_n \end{bmatrix} = p + n \quad (31)$$

Proof

For the proofs of this and following lemmas, the PBH rank test (Kailath 1980) is employed. Assume that (A, B) is stabilizable and (31) holds. For the stabilizability of (\tilde{A}, \tilde{B}) it suffices to show that for any complex $|\lambda| \geq 1$

$$\text{rank} [\tilde{A} - \lambda I_{p+n} : \tilde{B}] = \text{rank} \begin{bmatrix} (1 - \lambda)I_p & CA & CB \\ 0 & A - \lambda I_n & B \end{bmatrix} = p + n \quad (32)$$

Since $\text{rank} [A - \lambda I_n : B] = n$ for any complex $|\lambda| \geq 1$, we see that (32) holds for $\lambda \neq 1$. For the case of $\lambda = 1$, it follows from (31) that

$$\text{rank} \begin{bmatrix} CA & CB \\ A - I_n & B \end{bmatrix} = \text{rank} \left\{ \begin{bmatrix} I_p & C \\ 0 & I_n \end{bmatrix} \begin{bmatrix} 0 & C \\ B & A - I_n \end{bmatrix} \right\} = p + n \quad (33)$$

Thus we have shown that (32) holds for any complex $|\lambda| \geq 1$.

Now assume that (\tilde{A}, \tilde{B}) is stabilizable, so that (32) holds for any complex $|\lambda| \geq 1$. Since the matrix $[\tilde{A} - \lambda I_{p+n} : \tilde{B}]$ has a maximal row rank for any complex $|\lambda| \geq 1$, we see that $\text{rank} [A - \lambda I_n : B] = n$ for any complex $|\lambda| \geq 1$. Letting $\lambda = 1$ in (32) and using (33), we have (31). \square

A continuous-time version of Lemma 1a has been proved by Smith and Davison (1972) by manipulating the controllability matrix. It is also well known that the rank condition of (31) implies that the system (C, A, B) has no transmission zeros at $z = 1$ (Davison 1976).

Lemma 1b

The pair (\tilde{A}, \tilde{B}) is reachable if and only if (A, B) is reachable and the rank condition of (31) holds.

Proof

For the reachability of (\tilde{A}, \tilde{B}) , it suffices to show that (32) holds for any complex λ . Assume that (A, B) is reachable and (31) holds. It then follows that $\text{rank} [A - \lambda I_n : B] = n$ for any complex λ . Thus, for $\lambda \neq 1$, we can easily see that (32) holds. Moreover, for $\lambda = 1$, (33) holds as shown above. This implies that (\tilde{A}, \tilde{B}) is reachable. On the other hand, if (\tilde{A}, \tilde{B}) is reachable, then (32) holds for any complex λ . Hence, as in the proof of Lemma 1a, we have $\text{rank} [A - \lambda I_n : B] = n$ for any complex λ , and we have (31). This completes the proof of Lemma 1b. \square

By manipulating the controllability matrix, Seraji (1983) has proved Lemma 1b, and Young and Willems (1972) and Smith and Davison (1972) have proved the continuous-time version of Lemma 1b.

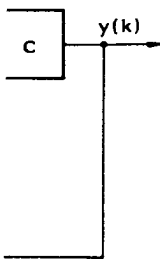

ve need some
stability (or

Now let H_e and H_x be $p \times p$ and $n \times n$ matrices such that $Q_e = H_e^T H_e$ and $Q_x = H_x^T H_x$ respectively. Then we have

$$\tilde{Q} = \tilde{H}^T \tilde{H} \quad (34)$$

where

$$\tilde{H} = \begin{bmatrix} H_e & 0 \\ 0 & H_x \end{bmatrix} \quad (35)$$

Lemma 2a

Let Q_e be positive definite. If (C, A) is detectable, then (\tilde{H}, \tilde{A}) is detectable.

Proof

We can easily see that (CA, A) is detectable if and only if (C, A) is detectable. For the detectability of (\tilde{H}, \tilde{A}) it suffices to show that for any complex $|\lambda| \geq 1$

$$\text{rank} \begin{bmatrix} \tilde{H} \\ \tilde{A} - \lambda I_{p+n} \end{bmatrix} = \text{rank} \begin{bmatrix} H_e & 0 \\ 0 & H_x \\ (1-\lambda)I_p & CA \\ 0 & A - \lambda I_n \end{bmatrix} = p + n \quad (36)$$

Suppose that (C, A) is detectable and hence (CA, A) is detectable. Then for any complex $|\lambda| \geq 1$

$$\text{rank} \begin{bmatrix} CA \\ A - \lambda I_n \end{bmatrix} = n \quad (37)$$

But since $\text{rank } H_e = \text{rank } Q_e = p$, it follows from (37) that (36) holds for any complex $|\lambda| \geq 1$. \square

Lemma 2b

Let Q_e be positive definite, and assume that A is non-singular. Then if (C, A) is observable, (\tilde{H}, \tilde{A}) is observable.

Proof

Suppose that (C, A) is observable. Since A is non-singular, (CA, A) is observable if and only if (C, A) is observable. Therefore (37) holds for any complex λ , so that we see from $\text{rank } H_e = p$ that (36) holds for any complex λ . This implies that (\tilde{H}, \tilde{A}) is observable. \square

It should be noted that if $Q_x = 0$, then Lemmas 2a and 2b give necessary and sufficient conditions for the detectability and observability of (\tilde{H}, \tilde{A}) respectively.

5. Proper
In this
(30).

Theorem 3a

Suppose

(a) Q_e a

(b) the 1

(c) $(A, \dots$

(d) $(C, \dots$

Then the ϵ
solution \tilde{K} ,
plane, nam

Proof

From I
detectable.

is well defin
the linear c

Theorem 3b

Suppose
assume tha

(c') $(A, \dots$

(d') $(C, \dots$

Then the st
has the uni

Proof

It follow
observable.
1972).

Remark 1

It should
asymptotica
to that of th
control pro

Remark 2

It follow

5. Property of feedback system

In this section, we consider the stability of the closed-loop system described by (30).

Theorem 3a

Suppose that the following conditions are satisfied:

- (a) Q_e and R are positive definite,
- (b) the rank condition of (31) holds

$$\text{rank} \begin{bmatrix} 0 & C \\ B & A - I_n \end{bmatrix} = p + n \tag{31}$$

- (c) (A, B) is stabilizable,
- (d) (C, A) is detectable.

Then the algebraic Riccati equation of (18) has the unique non-negative definite solution \tilde{K} , and the eigenvalues of \tilde{A}_c of (20) are all inside the unit circle in the complex plane, namely \tilde{A}_c is asymptotically and exponentially stable.

Proof

From Lemmas 1a and 2a, it follows that (\tilde{A}, \tilde{B}) is stabilizable and (\tilde{H}, \tilde{A}) is detectable. Furthermore, since R is positive definite the algebraic Riccati equation

$$\tilde{K} = \tilde{A}^T \tilde{K} \tilde{A} - \tilde{A}^T \tilde{K} \tilde{B} [R + \tilde{B}^T \tilde{K} \tilde{B}]^{-1} \tilde{B}^T \tilde{K} \tilde{A} + \tilde{H}^T \tilde{H} \tag{18'}$$

is well defined. Thus the theorem is proved by applying the well-known theorem for the linear quadratic regulator (Kucera 1972, Kwakernaak and Sivan 1972). \square

Theorem 3b

Suppose that the conditions (a) and (b) of Theorem 3a are satisfied. Moreover, assume that:

- (c') (A, B) is reachable,
- (d') (C, A) is observable and A is non-singular.

Then the statement of Theorem 3a holds, except that the algebraic Riccati equation has the unique positive definite solution.

Proof

It follows from Lemmas 1b and 2b that (\tilde{A}, \tilde{B}) is reachable and (\tilde{H}, \tilde{A}) is observable. The rest of the proof is standard (Kucera 1972, Kwakernaak and Sivan 1972). \square

Remark 1

It should be noted that the condition of (31) implies that $r \geq p$. Thus for \tilde{A}_c to be asymptotically stable, the number of control variables must be greater than or equal to that of the output variables to be controlled. This is quite common in practical control problems.

Remark 2

It follows from (17 c), (17 d) and (19) that the preview gains are given by

$$G_d(l) = - [R + \tilde{B}^T \tilde{K} \tilde{B}]^{-1} \tilde{B}^T (\tilde{A}_c^T)^{l-1} \tilde{K} \tilde{I}, \quad l = 1, \dots, N_L \tag{38}$$

Thus, under the assumption of Theorem 3a or 3b, the information on the future values of the demand vector becomes less important as l increases, since \tilde{A}_c is exponentially stable.

Now we show that under the assumption of Theorem 3a or 3b, a complete regulation occurs for the optimal closed-loop system.

Theorem 4

Assume that the conditions of either Theorem 3a or 3b are satisfied. If the demand vector is a step function, then a complete regulation occurs

$$\lim_{k \rightarrow \infty} e(k) = 0 \quad (\text{exponentially}) \quad (39)$$

and also

$$\lim_{k \rightarrow \infty} x(k) = \bar{x} \quad \text{and} \quad \lim_{k \rightarrow \infty} u^o(k) = \bar{u} \quad (40)$$

where \bar{x} and \bar{u} are constant vectors related by

$$\left. \begin{aligned} \bar{x} &= A\bar{x} + B\bar{u} + E\bar{w} \\ \bar{y}_d &= C\bar{x} \end{aligned} \right\} \quad (41)$$

and where $w(k) = \bar{w}$ for $k > 0$.

Proof

By taking the increment of (30), or by substituting $\Delta u^o(k)$ from (16) into (8), it follows that

$$\xi(k+1) = \tilde{A}_c \xi(k) + f(k) \quad (42)$$

where $\xi(k) = [e^T(k) \quad \Delta x^T(k)]^T$, and

$$f(k) = -\tilde{T} \Delta y_d(k+1) - \tilde{B} \sum_{l=1}^{N_L} G_d(l) \Delta y_d(k+l) \quad (43)$$

Since the demand vector is a step function, we have $\Delta y_d(k+l) = 0$ for any l . Thus $f(k) \equiv 0$, so that (42) reduces to $\xi(k+1) = \tilde{A}_c \xi(k)$. But since \tilde{A}_c is exponentially stable from Theorem 3a or 3b, it follows that

$$\lim_{k \rightarrow \infty} \xi(k) = 0$$

so that

$$\lim_{k \rightarrow \infty} e(k) = 0 \quad \text{and} \quad \lim_{k \rightarrow \infty} \Delta x(k) = 0$$

By using (16), we have

$$\lim_{k \rightarrow \infty} \Delta u^o(k) = 0$$

Thus we have shown (40); moreover from (1) and (2), we have (41). \square

Theorem 5

Assume that the conditions of either Theorem 3a or 3b are satisfied. If the demand vector satisfies

$$\lim_{k \rightarrow \infty} y_d(k) = \bar{y}_d \quad (44)$$

then a cc
(41). T
depends

Proof

A pr
 $k \rightarrow \infty$ in

Remark
It ma

the rank
that if p
and R .
weights.
are great
and \bar{x} w

Remark
We 1
preserve
Theorem
the prese
insensitiv
perturba

6. Obs
When
introduc
vector (C
is given

where y_n
matrix.
output v
called th
Since

then a complete regulation also occurs, namely $e(k) \rightarrow 0$ as $k \rightarrow \infty$, and we have (40) and (41). The convergence of $e(k)$ is, however, not necessarily exponential, since it depends on the rate of convergence of demand vector $y_d(k)$.

Proof

A proof is immediate by noting that \tilde{A}_c is exponentially stable and that $f(k) \rightarrow 0$ as $k \rightarrow \infty$ in (42). \square

Remark 3

It may be noted that since (41) can be written as

$$\begin{bmatrix} 0 & C \\ B & A - I_n \end{bmatrix} \begin{bmatrix} \bar{u} \\ \bar{x} \end{bmatrix} = \begin{bmatrix} \bar{y}_d \\ -E\bar{w} \end{bmatrix} \quad (45)$$

the rank condition of (31) implies that there exist \bar{u} and \bar{x} for given \bar{y}_d and \bar{w} . Note that if $p = r$, then the steady states \bar{u} and \bar{x} are independent of the quadratic weights \bar{Q} and R . The transient responses, however, depend heavily on the quadratic weights. It should also be noted that if $r > p$, namely the number of control variables are greater than that of the output variables to be controlled, then the steady states \bar{u} and \bar{x} will be affected by the quadratic weights.

Remark 4

We note here that the asymptotic stability of a dynamic system is generally preserved for small perturbations in the system parameters. Thus it follows from Theorem 4 or 5 that a complete regulation occurs for the closed-loop system of (30) in the presence of small perturbations in A , B , C and E matrices, namely the controller is insensitive to small change in system parameters. Furthermore, the arbitrary perturbations are allowed as long as the closed-loop system is asymptotically stable.

6. Observer-based controller

When the state vector $x(k)$ is not directly measurable, we are led to the introduction of an observer or a Kalman filter to obtain the estimate of the state vector (O'Reilly 1983). In this section, we assume that the measurable output vector is given by

$$y_m(k) = C_m x(k) \quad (46)$$

where $y_m(k)$ is the $m \times 1$ measurable output vector, and C_m is the $m \times m$ constant matrix. Usually the $p \times 1$ output vector to be regulated is a part of the measurable output vector, so that there exists the $p \times m$ matrix M such that $C = MC_m$. This is called the 'readability condition' (Francis and Wonham 1976).

Since $w(k)$ is constant, we have

$$\begin{bmatrix} x(k+1) \\ w(k+1) \end{bmatrix} = \begin{bmatrix} A & E \\ 0 & I_q \end{bmatrix} \begin{bmatrix} x(k) \\ w(k) \end{bmatrix} + \begin{bmatrix} B \\ 0 \end{bmatrix} u^o(k) \quad (47)$$

$$y_m(k) = [C_m \quad 0] \begin{bmatrix} x(k) \\ w(k) \end{bmatrix} \quad (48)$$

Let Y_m^{k-1} be the measurements up to $k-1$, namely $Y_m^{k-1} = \{y_m(0), y_m(1), \dots, y_m(k-1)\}$. Let $\hat{x}(k)$ and $\hat{w}(k)$ be the estimates of $x(k)$ and $w(k)$ based on the measurements Y_m^{k-1} respectively. Then the full-order observer for the system of (47) and (48) is given by

$$\begin{bmatrix} \hat{x}(k+1) \\ \hat{w}(k+1) \end{bmatrix} = \begin{bmatrix} A & E \\ 0 & I_q \end{bmatrix} \begin{bmatrix} \hat{x}(k) \\ \hat{w}(k) \end{bmatrix} + \begin{bmatrix} L_x \\ L_w \end{bmatrix} [y_m(k) - C_m \hat{x}(k)] + \begin{bmatrix} B \\ 0 \end{bmatrix} \hat{u}^o(k) \quad (49)$$

where L_x and L_w are $n \times m$ and $q \times m$ constant gain matrices respectively, which are determined so that the $(n+q) \times (n+q)$ matrix

$$\tilde{A}_L = \begin{bmatrix} A - L_x C_m & E \\ -L_w C_m & I_q \end{bmatrix} \quad (50)$$

is asymptotically stable (O'Reilly 1983). It should be noted that $\hat{u}^o(k)$ in (49) is obtained by replacing $x(k)$ by $\hat{x}(k)$ in (21) or (26).

Lemma 3

The pair

$$\left\{ [C_m \quad 0], \begin{bmatrix} A & E \\ 0 & I_q \end{bmatrix} \right\} \quad (51)$$

is detectable (observable) if and only if (C_m, A) is detectable (observable) and the following rank condition holds

$$\text{rank} \begin{bmatrix} C_m & 0 \\ I_n - A & E \end{bmatrix} = n + q \quad (52)$$

Proof

Assume that (C_m, A) is detectable and (52) holds. For the detectability of the pair (51), it suffices to show that for any complex $|\lambda| \geq 1$

$$\text{rank} \begin{bmatrix} C_m & 0 \\ \lambda I_n - A & -E \\ 0 & (\lambda - 1)I_q \end{bmatrix} = n + q \quad (53)$$

Since

$$\text{rank} \begin{bmatrix} C_m \\ \lambda I_n - A \end{bmatrix} = n \quad (54)$$

for any complex $|\lambda| \geq 1$, (53) holds for any complex $\lambda \neq 1$. For $\lambda = 1$, (53) also holds from (52). Conversely, if (53) holds for any complex $|\lambda| \geq 1$, then, as in the proof of Lemma 1b, we can easily see that (C_m, A) is detectable and (52) holds. The observability part of the lemma can be proved similarly. \square

The continuous-time version of the observability part is proved by Young and Willems (1972). It should also be noted that the rank condition of (52) implies that the system (C_m, A, E) has no transmission zeros at $z = 1$ (Davison 1976), and that

$m \geq q$,
unmeas

Lemma
If (C
can find

Proof
A I
(observ.

Nov
Then, fi

If we en
then we

since \hat{x}
zero, sc
Sub

Therefo

Theorem
Sup
(52) hold
that

Hence ϵ

$m \geq q$, namely the number of output variables is not less than that of the unmeasurable disturbances.

Lemma 4

If (C_m, A) is detectable (observable) and the rank condition of (52) holds, then we can find suitable gains L_x and L_w such that \tilde{A}_L of (48) is asymptotically stable.

Proof

A proof is immediate from Lemma 3 and the definition of detectability (observability). \square

Now define the estimation errors by $\tilde{x}(k) = x(k) - \hat{x}(k)$ and $\tilde{w}(k) = w(k) - \hat{w}(k)$. Then, from (47)–(50), we have

$$\begin{bmatrix} \tilde{x}(k+1) \\ \tilde{w}(k+1) \end{bmatrix} = \tilde{A}_L \begin{bmatrix} \tilde{x}(k) \\ \tilde{w}(k) \end{bmatrix} \tag{55}$$

If we employ the estimate $\hat{x}(k)$ in place of the state vector $x(k)$ in the controller of (26), then we have

$$\hat{u}^o(k) = u^o(k) + G_x \tilde{x}(k) \tag{56}$$

since $\hat{x}(k) = x(k) - \tilde{x}(k)$. However, if \tilde{A}_L is asymptotically stable, $\tilde{x}(k)$ converges to zero, so that the controller $\hat{u}^o(k)$ is asymptotically equivalent to $u^o(k)$.

Substituting (56) into (28) and combining the resultant system with (55) yields

$$\begin{bmatrix} v(k+1) \\ x(k+1) \\ \dots \\ \tilde{x}(k+1) \\ \tilde{w}(k+1) \end{bmatrix} = \begin{bmatrix} \tilde{A}_c & \tilde{B}G_x & 0 \\ \dots & \dots & \dots \\ 0 & \dots & \tilde{A}_L \end{bmatrix} \begin{bmatrix} v(k) \\ x(k) \\ \dots \\ \tilde{x}(k) \\ \tilde{w}(k) \end{bmatrix} + \begin{bmatrix} \tilde{E} \\ \dots \\ 0 \end{bmatrix} w(k) - \begin{bmatrix} \tilde{B} \\ \dots \\ 0 \end{bmatrix} \sum_{l=1}^{N_L} G_d(l) y_d(k+l) - \begin{bmatrix} \tilde{I} \\ \dots \\ 0 \end{bmatrix} y_d(k+1) \tag{57}$$

Therefore we have the following theorem.

Theorem 6

Suppose that the conditions of Theorem 3a are satisfied. If the rank condition of (52) holds, and if the demand vector $y_d(k)$ converges to \bar{y}_d , then there exist \bar{v} and \bar{x} such that

$$\lim_{k \rightarrow \infty} v(k) = \bar{v} \quad \text{and} \quad \lim_{k \rightarrow \infty} x(k) = \bar{x} \tag{58}$$

Hence a complete regulation is achieved under the observer-based controller of $\hat{u}^o(k)$.

Proof

It follows from Theorem 3a and Lemma 4 that the $(p + 2n + q) \times (p + 2n + q)$ matrix

$$\begin{bmatrix} \tilde{A}_c & \tilde{B}G_x & 0 \\ 0 & \tilde{A}_L & \end{bmatrix} \quad (59)$$

becomes exponentially stable. Since $w(k)$ is constant, and $y_d(k) \rightarrow \bar{y}_d$, the rest of the proof is immediate. \square

Remark 5

Conditions (b), (c) and (d) of Theorem 3a together with the readability condition ($C = MC_m$) are equivalent to the necessary and sufficient conditions for the existence of a robust controller for the system of (1), (2) and (46) (Davison and Goldenberg 1975, Davison 1976).

Remark 6

As in Remark 4, the observer-based controller of (56) achieves a complete regulation under small perturbations of system parameters. However, it is to be noted that the robustness of the LQ regulator is not preserved for the case when a state observer or a Kalman filter is introduced into the state feedback loop (Doyle and Stein 1979, O'Reilly 1983).

7. Numerical example

In this section, we apply the present technique to the design of an optimal controller for a power plant model. A discrete-time model of a typical large-scale supercritical once-through steam generator is given by

$$x(k+1) = Ax(k) + Bu(k) \quad (60)$$

$$y_m(k) = C_m x(k) \quad (61)$$

where the sampling interval is 20 s, and where $x(k)$ is the 20×1 state vector, $u(k)$ is the 6×1 control vector and $y_m(k)$ is the 10×1 measurable outputs; thus we have $n = 20$, $r = 6$, $m = 10$. Matrices A , B and C_m are given by (B 1)–(B 3) in Appendix B (Katayama et al. 1984). The description of the input and output variables are shown in Table 1, and a schematic diagram of the input–output model is shown in Fig. 2. Among ten measurable output variables, six variables MST, TPL, TP, MW, RHT and NOX are considered as the outputs to be regulated, so that we have $p = 6$ and

$$y_1(k) := y_{m1}(k), \quad y_2(k) := y_{m2}(k), \quad y_3(k) := y_{m6}(k)$$

$$y_4(k) := y_{m7}(k), \quad y_5(k) := y_{m8}(k), \quad y_6(k) := y_{m9}(k)$$

Therefore C becomes a 6×20 matrix formed by deleting the third, fourth, fifth and tenth rows from the matrix C_m of (B 3), so that \tilde{A} , \tilde{B} , \tilde{Q} and R are of dimension 26×26 , 26×6 , 26×26 and 6×6 respectively.

We assume that the desired values of MST, TPL, RHT and NOX are the average

Outputs

y_{m1}
 y_{m2}
 y_{m3}
 y_{m4}
 y_{m5}
 y_{m6}
 y_{m7}
 y_{m8}
 y_{m9}
 y_{m10}

Inputs

u_1
 u_2
 u_3
 u_4
 u_5
 u_6
 u_7

values \bar{u}
 is chan
 deman
 operati

The
 R and 1
 26×26
 depict 1

$p + 2n + q$
(59)
rest of the \square
condition
existence
berg 1975,

complete
it is to be
se when a
Doyle and

n optimal
arge-scale
(60)
(61)

$u(k)$ is the
ve $n = 20$,
pendix B
are shown
shown in
TP, MW,
ave $p = 6$

fifth and
n 26×26 ,
e average

Name	Description (average value at 50% load)
Outputs	
y_{m1}	MST Main steam temperature at turbine inlet (538° C)
y_{m2}	TPL Platen superheater outlet temperature (502° C)
y_{m3}	T1SH Primary superheater outlet temperature (456° C)
y_{m4}	TF Furnace pass outlet temperature (395° C)
y_{m5}	TECO Economizer outlet temperature (291° C)
y_{m6}	TP Main stream pressure (174 kgf/cm ²)
y_{m7}	MW Generator output (250 MW)
y_{m8}	RHT Reheater output steam temperature (556° C)
y_{m9}	NOX NO _x content in exhaust gas (102 ppm)
y_{m10}	O2 O ₂ content in exhaust gas (2.49%)
Inputs	
u_1	QFW Feedwater flow (760 t/h)
u_2	QFO Fuel flow (55.9 t/h)
u_3	LGD Reheater gas damper position (59.6%)
u_4	LTV Turbine control valve position (61.0%)
u_5	GMF Damper position for gas mixing fan (20.1%)
u_6	QSP2 Secondary spray flow (36.2 t/h)
u_7	QAIR Air flow (39.6%)

Table 1. Description of input and output variables

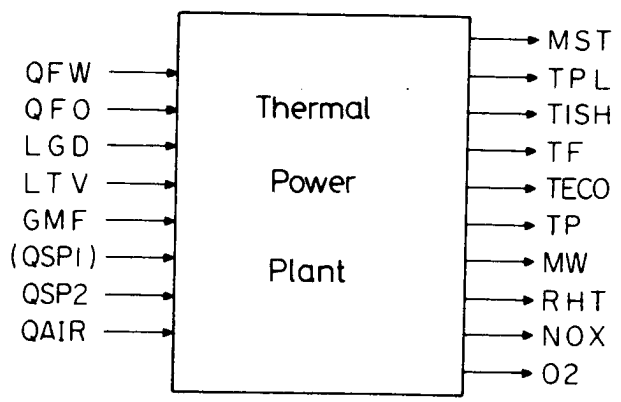

Figure 2. Schematic diagram of input-output model.

values at 50% load condition (see Table 1). Also, we assume that the demand for MW is changed from 50% load to 75% load at 5%/min rate, starting at $k = 10$. The demand for TP is determined according to the program of variable-pressure operation (see Fig. 3 (a)).

The closed-loop responses are computed for various quadratic weights Q_e , Q_x and R and the preview lengths N_L . The algebraic matrix Riccati equation of dimension 26×26 is solved via the real Schur method due to Laub (1979). Figures 3 (a)-(e) depict the closed-loop responses for

$$\left. \begin{aligned} Q_e &= \text{diag} (2, 1, 3, 3, 4, 1) \\ Q_x &= 0 \\ R &= \text{diag} (0.1, 0.1, 10, 0.1, 10, 1) \end{aligned} \right\} \quad (62)$$

It should be noted in Figs. 3 (a)–(e) that all the responses are shown as the deviations from the average values at 50% load condition. The solid and dashed curves represent the responses for $N_L = 5$ and $N_L = 1$ respectively. Table 2 displays the mean square errors of the controlled variables

$$J_\alpha = \sum_{k=0}^{300} e_\alpha^2(k), \quad \alpha = 1, \dots, 6 \quad (63)$$

where $N_L = 0, 1, \dots, 5$, and the quadratic weights of (62) are employed. We can clearly see from Fig. 3 and Table 2 that the preview action is very effective for

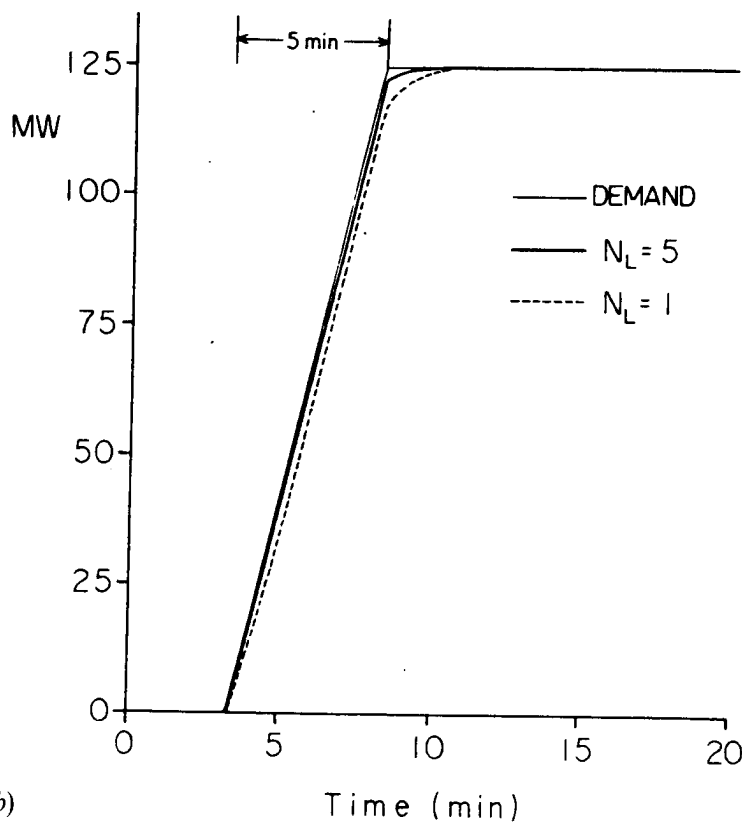
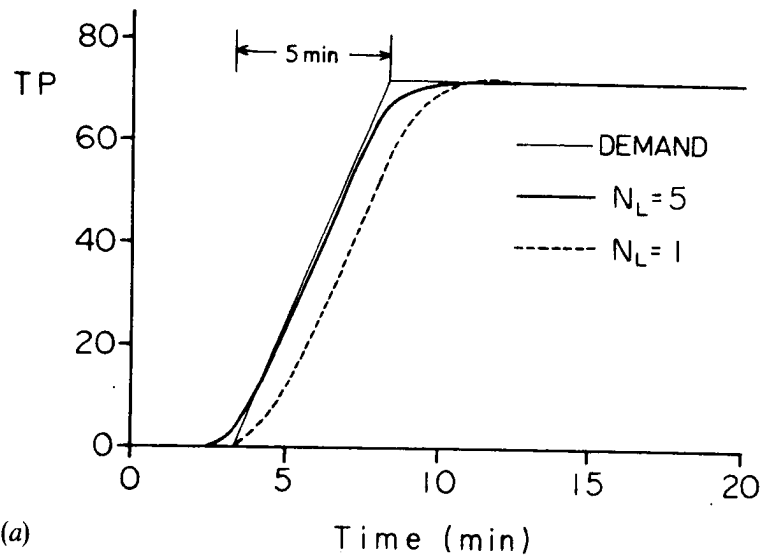

variations
curves
says the

(63)

We can
give for

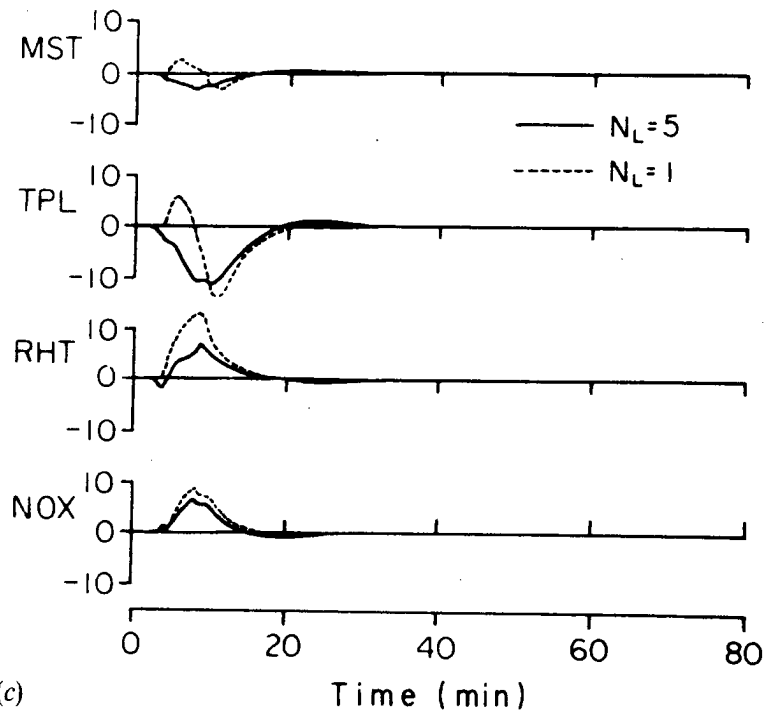

(c)

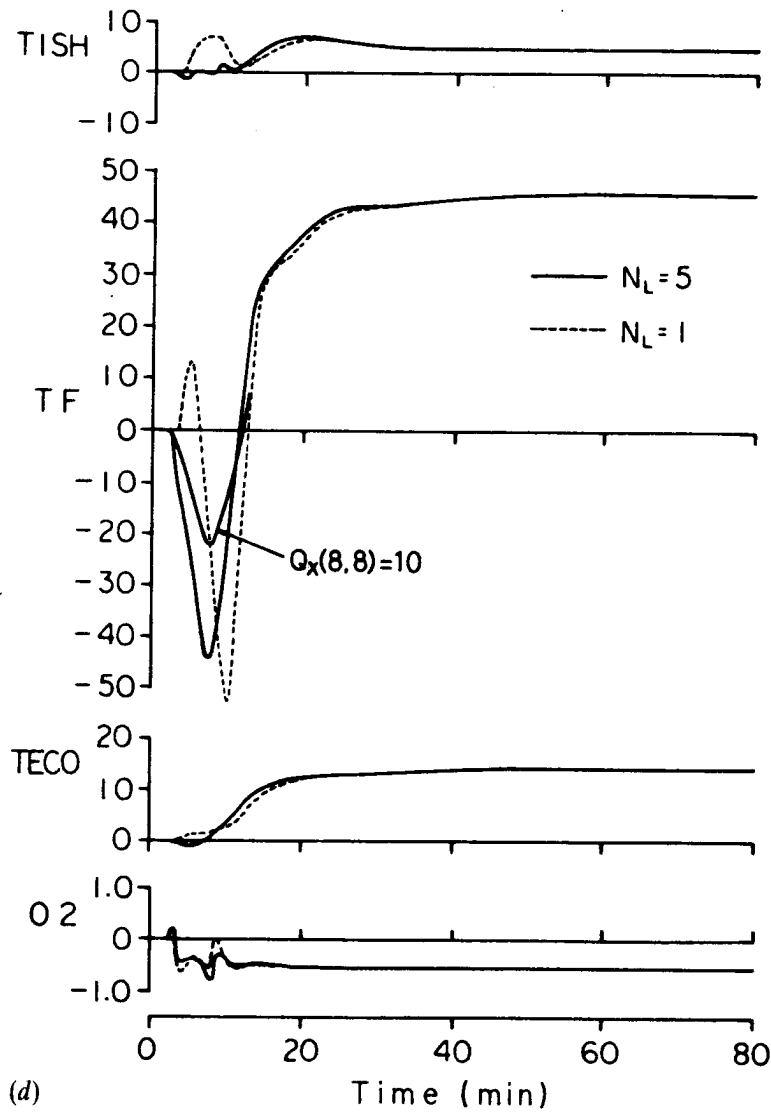

(d)

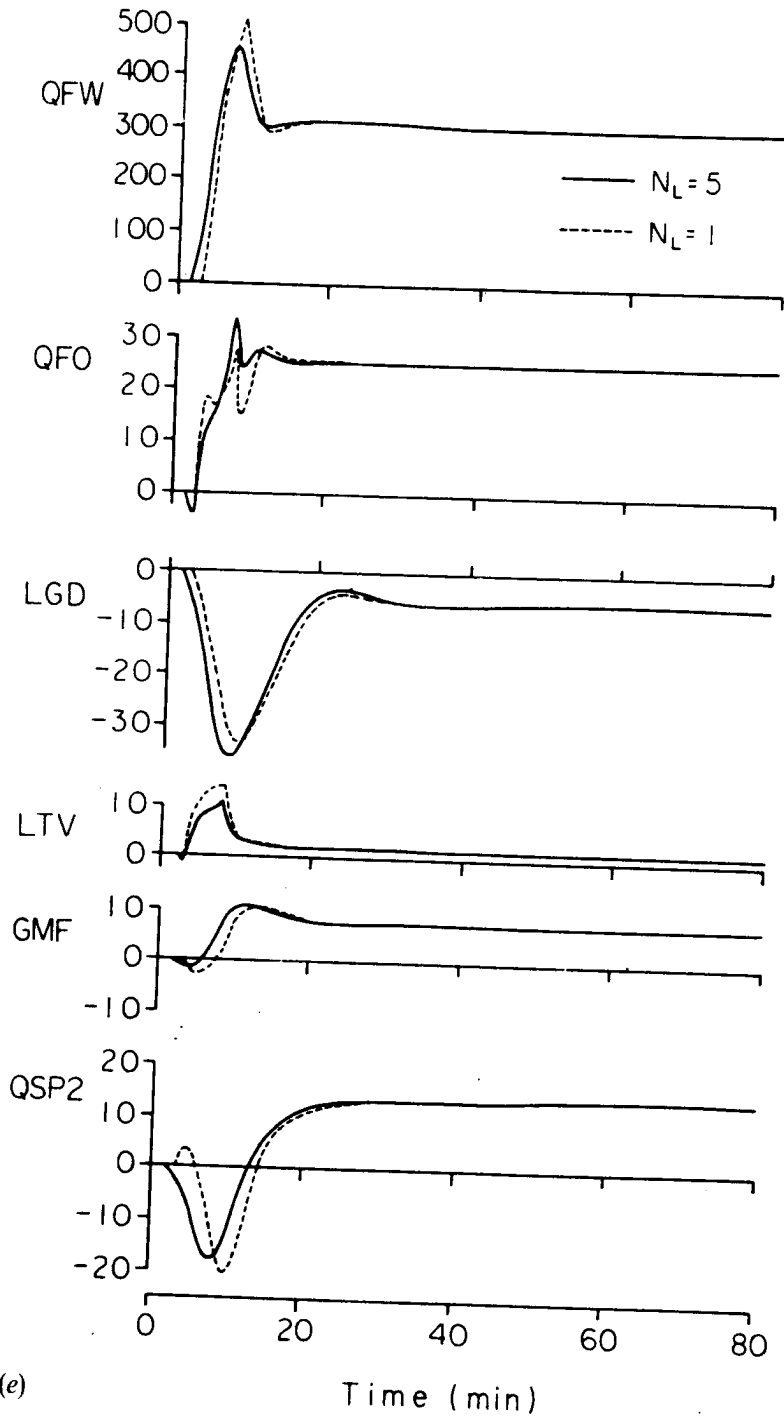

Figure 3. Closed-loop responses: (a) main steam pressure TP, (b) generator output MW, (c) controlled variables MST, TPL, RHT and NOX, (d) measurable outputs T1SH, TF, TECO and O2, (e) control variables QFW, QFO, LGD, LTV, GMF and QSP2.

improving the load following capability of the plant, although the performance of MST and TPL is not improved by the preview actions. Further we observe that the variations of other output variables become smoother by introducing the preview action.

Since the excursion of TF is very large, as shown in Fig. 3 (d), we set $Q_x(8, 8) = 10$ to regulate the transient response of TF, while keeping Q_e and R as in (62) (note that $x_8(k) = y_{m4}(k)$). Then, as shown in Fig. 3 (d), the dip of TF is reduced from -44°C

N_L
0
1
2
3
4
5
5†

to -23
as sho
quadra
system.
servom

8. Co
This
state fe
variable
achieve
perturb
introdu
Numeri
view ac
system.
Furt
when ai

Appendi
A proof
It is

subject 1

has the

where \bar{K}

N_L	MST	TPL	TP	MW	RHT	NOX
0	116	2216	4750	3239	2024	979
1	116	2216	2737	700	2024	979
2	83	2124	1112	447	1450	830
3	91	2134	445	251	982	697
4	119	2207	174	136	686	586
5	136	2257	91	72	516	497
5†	140	1273	142	80	960	1408

$$\dagger Q_x(8, 8) = 10$$

Table 2. Mean square errors of controlled variables.

to -23°C at the expense of the performance of controlled variables, except for TPL, as shown in the bottom line of Table 2. Further adjustment of the values of quadratic weights could improve the transient responses of the closed-loop system. Therefore we see that the present method is effective for designing a servomechanism for a multivariable linear system.

8. Conclusions

This paper has presented a method of designing an optimal servo controller with state feedback plus integral and preview actions for a discrete-time linear multivariable system. It is shown under the mild conditions that the closed-loop system achieves a complete regulation in the presence of a step disturbance and small perturbations in system parameters. It is also shown that when an observer is introduced into the state feedback loop, a complete regulation also occurs. Numerical results show that the present design method is flexible and that the preview action is very effective for improving the transient responses of the closed-loop system.

Further studies are needed on the robustness issue for the closed-loop system when an observer or a Kalman filter is incorporated into the state feedback loop.

Appendix A

A proof of Theorem 1

It is well known (Kwakernaak and Sivan 1972) that the problem of minimizing

$$J = \sum_{i=k}^{\infty} [\bar{x}^T(i)\bar{Q}\bar{x}(i) + \Delta u^T(i)R\Delta u(i)] \quad (\text{A } 1)$$

subject to the dynamic constraint

$$\bar{x}(i+1) = \bar{A}\bar{x}(i) + \bar{B}\Delta u(i) \quad (\text{A } 2)$$

has the optimal solution

$$u^0(i) = -[R + \bar{B}^T\bar{K}\bar{B}]^{-1}\bar{B}^T\bar{K}\bar{A}\Delta\bar{x}(i), \quad i = k, k+1, \dots \quad (\text{A } 3)$$

where \bar{K} is the non-negative definite solution of the algebraic matrix Riccati equation

$$\bar{K} = \bar{A}^T\bar{K}\bar{A} - \bar{A}^T\bar{K}\bar{B}[R + \bar{B}^T\bar{K}\bar{B}]^{-1}\bar{B}^T\bar{K}\bar{A} + \bar{Q} \quad (\text{A } 4)$$

put MW,
1SH, TF,
SP2.

nance of
that the
preview

3, 8) = 10
note that
- 44° C

and where

$$\bar{A} = \begin{bmatrix} \tilde{A} & \tilde{V} \\ 0 & A_d \end{bmatrix}_{[(p+n+pN_L) \times (p+n+pN_L)]} \tag{A 5}$$

$$\tilde{V} = [-\tilde{I} : 0 : \dots : 0]_{[(p+n) \times pN_L]} \tag{A 6}$$

$$\bar{B} = \begin{bmatrix} \tilde{B} \\ 0 \end{bmatrix}_{[(p+n+pN_L) \times r]} \tag{A 7}$$

$$\bar{Q} = \begin{bmatrix} \tilde{Q} & 0 \\ 0 & 0 \end{bmatrix} \tag{A 8}$$

We partition the $(p+n+pN_L) \times (p+n+pN_L)$ matrix \bar{K} as

$$\bar{K} = \begin{bmatrix} \tilde{K} & \tilde{X} \\ \tilde{X}^T & \tilde{Z} \end{bmatrix} \tag{A 9}$$

Then it follows from (A 5), (A 7) and (A 9) that

$$R + \bar{B}^T \bar{K} \bar{B} = R + \tilde{B}^T \tilde{K} \tilde{B} \tag{A 10}$$

$$\bar{B}^T \bar{K} \bar{A} = [\tilde{B}^T \tilde{K} \tilde{A} : \tilde{B}^T \tilde{K} \tilde{V} + \tilde{B}^T \tilde{X} A_d] \tag{A 11}$$

Hence we see from (A 3) that the optimal control is expressed as

$$\begin{aligned} \Delta u^o(i) = & -[R + \tilde{B}^T \tilde{K} \tilde{B}]^{-1} \tilde{B}^T \tilde{K} \tilde{A} \begin{bmatrix} e(i) \\ \Delta x(i) \end{bmatrix} \\ & - [R + \tilde{B}^T \tilde{K} \tilde{B}]^{-1} \tilde{B}^T (\tilde{K} \tilde{V} + \tilde{X} A_d) x_d(i) \end{aligned} \tag{A 12}$$

But it follows from (A 6) and (9) that

$$\tilde{V} x_d(i) = -\tilde{I} \Delta y_d(i+1) \tag{A 13}$$

$$\tilde{X} A_d x_d(i) = \tilde{X} \begin{bmatrix} \Delta y_d(i+2) \\ \vdots \\ \Delta y_d(i+N_L) \\ 0 \end{bmatrix} = \sum_{l=2}^{N_L} \tilde{X}(l-1) \Delta y_d(i+l) \tag{A 14}$$

where

$$\tilde{X} = [\tilde{X}(1) : \tilde{X}(2) : \dots : \tilde{X}(N_L)]_{[(p+n) \times pN_L]} \tag{A 15}$$

Therefore, noting that $\tilde{A} = [\tilde{I} \quad \tilde{F}]$, we see from (A 12)–(A 14) that

$$\Delta u^o(i) = -G_I e(i) - G_x \Delta x(i) - \sum_{l=1}^{N_L} G_d(l) \Delta y_d(i+l), \quad i = k, k+1, \dots \tag{A 16}$$

where $G_I, G_x, G_d(l)$ are given by (17 a)–(17 d). Putting $i = k$ in (A 16), we have (16).

We now turn to the proof of (18) and (19). It follows from (A 5) and (A 9) that

$$\bar{A}^T \bar{K} \bar{A} = \begin{bmatrix} \bar{A}^T \tilde{K} \tilde{A} & \vdots & \bar{A}^T \tilde{K} \tilde{V} + \bar{A}^T \tilde{X} A_d \\ \dots & \dots & \dots \\ \tilde{V}^T \tilde{K} \tilde{A} + A_d^T \tilde{X}^T \tilde{A} & \vdots & \tilde{V}^T \tilde{K} \tilde{V} + A_d^T \tilde{X} A_d + \tilde{V}^T \tilde{X} A_d + A_d^T \tilde{X}^T \tilde{V} \end{bmatrix} \tag{A 17}$$

Also, by

$$\bar{A}^T \bar{K} \bar{B}$$

It follow equatio:

But we

Thus u:

where

This co

Appen
Ma

$$A = \begin{bmatrix} 0 & -0.4 \\ 1 & 1.4 \\ 0 & 0.0 \\ 0 & -0.0 \\ 0 & 0.0 \\ 0 & -0.0 \\ 0 & 0.1 \\ 0 & -0.1 \\ 0 & 0.0 \\ 0 & -0.0 \\ 0 & 0.0 \\ 0 & 0.0 \\ 0 & 0.0 \\ 0 & -0.0 \\ 0 & -0.0 \\ 0 & 0.0 \\ 0 & 0.0 \\ 0 & 0.0 \\ 0 & 0.0 \\ 0 & 0.0 \\ 0 & 0.0 \end{bmatrix}$$

Also, by using (A 10) and (A 11)

(A 5)

(A 6)

(A 7)

(A 8)

$$\bar{A}^T \bar{K} \bar{B} [R + \bar{B}^T \bar{K} \bar{B}]^{-1} \bar{B}^T \bar{K} \bar{A} = \begin{bmatrix} \bar{A}^T \bar{K} \\ \dots\dots\dots \\ \bar{V}^T \bar{K} + A_d^T \bar{X}^T \end{bmatrix} \bar{B} [R + \bar{B}^T \bar{K} \bar{B}]^{-1} \bar{B}^T [\bar{K} \bar{A} : \bar{K} \bar{V} + \bar{X} A_d] \tag{A 18}$$

It follows from (A 17), (A 18) and (A 8) that the (1, 1)-block of the algebraic Riccati equation of (A 4) reduces to (18). Also, the (1, 2)-block of (A 4) becomes

$$\bar{X} = \bar{A}^T (\bar{K} \bar{V} + \bar{X} A_d) - \bar{A}^T \bar{K} \bar{B} [R + \bar{B}^T \bar{K} \bar{B}]^{-1} \bar{B}^T (\bar{K} \bar{V} + \bar{X} A_d) \tag{A 19}$$

But we see from (A 6), (A 15) and (A 11) that

(A 9)

(A 10)

(A 11)

$$\left. \begin{aligned} \bar{K} \bar{V} &= [-\bar{K} \bar{I} : 0 : \dots : 0] \\ \bar{X} A_d &= [0 : \bar{X}(1) : \dots : \bar{X}(N_L - 1)] \end{aligned} \right\} \tag{A 20}$$

Thus using (A 20), the first block of (A 19) becomes

$$\begin{aligned} \bar{X}(1) &= -\bar{A}^T \bar{K} \bar{I} + \bar{A}^T \bar{K} \bar{B} [R + \bar{B}^T \bar{K} \bar{B}]^{-1} \bar{B}^T \bar{K} \bar{I} \\ &= -\bar{A}_c^T \bar{K} \bar{I} \end{aligned} \tag{A 21}$$

where \bar{A}_c is given by (20). Also, the l th block of (A 19) is expressed as

(A 12)

$$\bar{X}(l) = \bar{A}_c^T \bar{X}(l-1), \quad l = 2, \dots, N_L \tag{A 22}$$

This completes the proof of (19). □

(A 13)

(A 14)

Appendix B

Matrices A , B , C_m are given by

(A 15)

(A 16)

$$A = \begin{bmatrix} 0 & -0.4607 & 0 & 0.0045 & 0 & 0.1304 & 0 & 0.0731 & 0 & 0.0608 & 0 & 0.0178 & 0 & 0.0067 & 0 & -0.0090 & 0 & 0.0 & 0 & 0.0 \\ 1 & 1.4269 & 0 & 0.0034 & 0 & -0.1702 & 0 & -0.0728 & 0 & -0.0527 & 0 & -0.0595 & 0 & 0.0011 & 0 & 0.0065 & 0 & 0.0 & 0 & 0.0 \\ 0 & 0.0179 & 0 & -0.1242 & 0 & -0.1065 & 0 & -0.0351 & 0 & -0.0603 & 0 & -0.0939 & 0 & 0.0004 & 0 & 0.0693 & 0 & 0.0 & 0 & 0.0 \\ 0 & -0.0090 & 1 & 1.0126 & 0 & 0.2113 & 0 & 0.0411 & 0 & 0.0543 & 0 & 0.0521 & 0 & 0.0013 & 0 & -0.0728 & 0 & 0.0 & 0 & 0.0 \\ 0 & 0.0406 & 0 & -0.2096 & 0 & -0.0777 & 0 & 0.0492 & 0 & -0.0334 & 0 & -0.0421 & 0 & -0.0082 & 0 & -0.1448 & 0 & 0.0 & 0 & 0.0 \\ 0 & -0.0431 & 0 & 0.1458 & 1 & 1.1320 & 0 & -0.0392 & 0 & 0.0343 & 0 & 0.0290 & 0 & 0.0002 & 0 & 0.1535 & 0 & 0.0 & 0 & 0.0 \\ 0 & 0.1253 & 0 & 0.1610 & 0 & 0.0953 & 0 & -0.6278 & 0 & -0.0066 & 0 & 0.0144 & 0 & 0.0047 & 0 & 0.1116 & 0 & 0.0 & 0 & 0.0 \\ 0 & -0.1222 & 0 & -0.2340 & 0 & -0.0159 & 1 & 1.5797 & 0 & 0.0551 & 0 & -0.0192 & 0 & -0.0004 & 0 & -0.1173 & 0 & 0.0 & 0 & 0.0 \\ 0 & 0.0086 & 0 & -0.1020 & 0 & -0.1038 & 0 & 0.0057 & 0 & 0.1812 & 0 & -0.0301 & 0 & 0.0048 & 0 & -0.0517 & 0 & 0.0 & 0 & 0.0 \\ 0 & -0.0094 & 0 & 0.1284 & 0 & 0.0851 & 0 & -0.0079 & 1 & 0.7771 & 0 & 0.0253 & 0 & 0.0081 & 0 & 0.0529 & 0 & 0.0 & 0 & 0.0 \\ 0 & 0.0095 & 0 & -0.0669 & 0 & -0.0342 & 0 & 0.0658 & 0 & -0.0341 & 0 & 0.2095 & 0 & 0.0107 & 0 & 0.0923 & 0 & 0.0 & 0 & 0.0 \\ 0 & 0.0237 & 0 & 0.0813 & 0 & 0.0268 & 0 & -0.0848 & 0 & 0.0164 & 1 & 0.6173 & 0 & -0.0138 & 0 & -0.0945 & 0 & 0.0 & 0 & 0.0 \\ 0 & 0.0189 & 0 & -0.3275 & 0 & -0.1496 & 0 & 0.0689 & 0 & -0.1201 & 0 & 0.1359 & 0 & 0.3119 & 0 & -0.0085 & 0 & 0.0 & 0 & 0.0 \\ 0 & -0.0059 & 0 & 0.2417 & 0 & 0.1944 & 0 & -0.0739 & 0 & 0.3157 & 0 & 0.1776 & 0 & 0.3995 & 0 & 0.0516 & 0 & 0.0 & 0 & 0.0 \\ 0 & -0.0373 & 0 & 0.0986 & 0 & -0.1332 & 0 & 0.0657 & 0 & -0.0546 & 0 & 0.0440 & 0 & -0.0111 & 0 & -0.0391 & 0 & 0.0 & 0 & 0.0 \\ 0 & 0.0610 & 0 & -0.0931 & 0 & 0.1297 & 0 & -0.0714 & 0 & 0.0254 & 0 & -0.0848 & 0 & 0.0055 & 1 & 1.0233 & 0 & 0.0 & 0 & 0.0 \\ 0 & 0.0 & 0 & 0.0 & 0 & 0.0 & 0 & 0.0 & 0 & 0.0 & 0 & 0.0 & 0 & 0.0 & 0 & 0.0 & 0 & -0.1228 & 0 & 2.0351 \\ 0 & 0.0 & 0 & 0.0 & 0 & 0.0 & 0 & 0.0 & 0 & 0.0 & 0 & 0.0 & 0 & 0.0 & 0 & 0.0 & 1 & 0.8965 & 0 & 3.0747 \\ 0 & 0.0 & 0 & 0.0 & 0 & 0.0 & 0 & 0.0 & 0 & 0.0 & 0 & 0.0 & 0 & 0.0 & 0 & 0.0 & 0 & -0.0041 & 0 & 0.2600 \\ 0 & 0.0 & 0 & 0.0 & 0 & 0.0 & 0 & 0.0 & 0 & 0.0 & 0 & 0.0 & 0 & 0.0 & 0 & 0.0 & 0 & 0.0042 & 1 & 0.1704 \end{bmatrix} \tag{B 1}$$

ave (16).
A 9) that

(A 17)

$$B = \begin{bmatrix} -0.0026 & 0.1205 & -0.0022 & -0.0603 & 0.0091 & -0.0362 \\ 0.0010 & -0.0096 & 0.0038 & -0.0378 & 0.0004 & 0.0019 \\ -0.0025 & 0.0800 & -0.0014 & -0.0647 & 0.0188 & 0.0001 \\ -0.0011 & 0.0399 & 0.0034 & -0.0165 & 0.0057 & 0.0087 \\ -0.0014 & 0.0547 & -0.0205 & -0.0001 & 0.0070 & -0.0005 \\ -0.0004 & 0.0105 & 0.0056 & -0.0131 & -0.0014 & 0.0023 \\ -0.0086 & 0.0656 & 0.0191 & -0.0307 & -0.0617 & 0.0095 \\ -0.0101 & 0.2088 & -0.0095 & -0.0300 & 0.0038 & 0.0086 \\ -0.0033 & -0.0021 & -0.0294 & -0.0086 & 0.0035 & -0.0007 \\ 0.0013 & 0.0050 & 0.0187 & -0.0022 & -0.0013 & 0.0002 \\ 0.0081 & 0.0446 & -0.0092 & 0.0964 & 0.0258 & -0.0081 \\ 0.0244 & 0.1400 & 0.0039 & -0.5574 & -0.0419 & 0.0152 \\ 0.0147 & -0.1752 & -0.0013 & -1.2201 & -0.0057 & -0.0014 \\ 0.0103 & 0.2547 & 0.0006 & 1.9353 & -0.0402 & 0.0117 \\ 0.0008 & 0.1287 & 0.0077 & -0.1102 & 0.0106 & 0.0075 \\ 0.0006 & 0.0210 & 0.0002 & 0.0126 & 0.0066 & 0.0004 \\ 0.0 & 0.0901 & -0.0152 & 0.0 & -0.2026 & 0.0 \\ 0.0 & 0.0810 & 0.0026 & 0.0 & -0.0255 & 0.0 \\ 0.0 & 0.0544 & 0.0011 & 0.0 & -0.0037 & 0.0 \\ 0.0 & -0.0668 & -0.0035 & 0.0 & 0.0039 & 0.0 \end{bmatrix} \quad (B 2)$$

$$C_m = \begin{bmatrix} 0 & 1 & 0 & 0 & 0 & 0 & 0 & 0 & 0 & 0 & 0 & 0 & 0 & 0 & 0 & 0 & 0 & 0 \\ 0 & 0 & 0 & 1 & 0 & 0 & 0 & 0 & 0 & 0 & 0 & 0 & 0 & 0 & 0 & 0 & 0 & 0 \\ 0 & 0 & 0 & 0 & 0 & 1 & 0 & 0 & 0 & 0 & 0 & 0 & 0 & 0 & 0 & 0 & 0 & 0 \\ 0 & 0 & 0 & 0 & 0 & 0 & 0 & 1 & 0 & 0 & 0 & 0 & 0 & 0 & 0 & 0 & 0 & 0 \\ 0 & 0 & 0 & 0 & 0 & 0 & 0 & 0 & 0 & 1 & 0 & 0 & 0 & 0 & 0 & 0 & 0 & 0 \\ 0 & 0 & 0 & 0 & 0 & 0 & 0 & 0 & 0 & 0 & 0 & 1 & 0 & 0 & 0 & 0 & 0 & 0 \\ 0 & 0 & 0 & 0 & 0 & 0 & 0 & 0 & 0 & 0 & 0 & 0 & 1 & 0 & 0 & 0 & 0 & 0 \\ 0 & 0 & 0 & 0 & 0 & 0 & 0 & 0 & 0 & 0 & 0 & 0 & 0 & 0 & 1 & 0 & 0 & 0 \\ 0 & 0 & 0 & 0 & 0 & 0 & 0 & 0 & 0 & 0 & 0 & 0 & 0 & 0 & 0 & 0 & 1 & 0 \\ 0 & 0 & 0 & 0 & 0 & 0 & 0 & 0 & 0 & 0 & 0 & 0 & 0 & 0 & 0 & 0 & 0 & 1 \end{bmatrix} \quad (B 3)$$

Since usually the ratio QAIR/QFO is kept around 0.7 at partial load, it is assumed that $u_7(k) = 0.7u_2(k)$. Thus matrix B above is obtained by modifying as $b_2 := b_2 + 0.7b_7$ in Katayama *et al.* (1984), where b_i is the i th column.

REFERENCES

- ATHANS, M., 1971, *Automatica*, **7**, 643.
 BRADSHAW, A., and PORTER, B., 1976, *Int. J. Control*, **24**, 275.
 DAVISON, E. J., 1972, *I.E.E.E. Trans. autom. Control*, **17**, 621; 1976, *Ibid*, **21**, 25.
 DAVISON, E. J., and GOLDENBERG, A., 1975, *Automatica*, **11**, 461.
 DESOER, C. A., and WANG, Y. T., 1980, in *Control and Dynamic Systems*, Vol. 16, edited by C. T. Leondes (New York: Academic Press), p. 81.
 DOYLE, J. C., and STEIN, G., 1979, *I.E.E.E. Trans. autom. Control*, **24**, 607.
 FERREIRA, P. G., 1976, *Int. J. Control*, **23**, 245.
 FRANCIS, B. A., and WONHAM, W. M., 1976, *Automatica*, **12**, 457.
 FURUTA, K., and KOMIYA, K., 1982, *I.E.E.E. Trans. autom. Control*, **27**, 788.
 KAILATH, T., 1980, *Linear Systems* (Englewood Cliffs: Prentice-Hall).
 KATAYAMA, T., OHKI, T., INOUE, T., and NAKAYAMA, S., 1984, Preprints, 9th I.F.A.C. World Congress, Budapest, 2-6 July, Session 0.1.1/D.
 KUCERA, V., 1972, *Kybernetika* (Prague), **8**, 430.

KWAKERN
 In
 LAUB, A.
 O'REILLY,
 SERAJI, H.
 SMITH, H.
 TOMIZUKA
 TOMIZUKA
 YOUNG, P

62
19
01
87
05
23
95
86
07
02
81
52
14
17
75
04

(B 2)

0
0
0
0
0
0
0
0
0
0
1

(B 3)

KWAKERNAAK, H., and SIVAN, R., 1972, *Linear Optimal Control Systems* (New York: Wiley-Interscience).

LAUB, A. J., 1979, *I.E.E.E. Trans. autom. Control*, **24**, 913.

O'REILLY, J., 1983, *Observers for Linear Systems* (New York: Academic Press).

SERAJI, H., 1983, *Int. J. Control*, **38**, 843.

SMITH, H. W., and DAVISON, E. J., 1972, *Proc. Instn elect. Engrs*, **119**, 1210.

TOMIZUKA, M., 1975, *I.E.E.E. Trans. autom. Control*, **20**, 362.

TOMIZUKA, M., and ROSENTHAL, D. E., 1979, *Trans. Am. Soc. mech. Engrs, Pt. G*, **101**, 172.

YOUNG, P. C., and WILLEMS, J. C., 1972, *Int. J. Control*, **15**, 961.

is assumed
modifying as

ited by C. T.

E.A.C. World