

Special Systems Features Bulletin

Core Storage Clock and Interval Timer – RPQ F89349

The core storage clock and interval timer features consist of a permanently assigned storage location (location 0005) which is periodically incremented whenever an IBM 7090 Data Processing System is operating or is waiting to operate (whenever all power is on the system).

Incrementing is accomplished by interrupting the normal operating cycle of the central processing unit for two machine cycles, during which the contents of location 5 are read out of storage, incremented in the address, and placed back in storage location 5. Once the current time is stored in location 5, the contents represent a "time of day" clock. In addition, provision can be made to force a program trap whenever the contents of location 5 overflow its capacity. A short program will then permit the location to serve as both a time-of-day clock and an interval timer. The incrementing of location 5 is under control of a manual switch; therefore, existing programs using this location may be run without modification.

Figure 1 shows the operation of these features in block diagram form.

STORAGE CLOCK

Storage location 5 is incremented every 1/60 of a second. Incrementing occurs whenever complete operating power is on the system and the clock's manual switch is in the ON position. Cumulative error over a period of time corresponds to frequency variation of the 60 cycle power distributed throughout the 7090 system. Aside from this frequency variation, maximum error when interrogating the clock is 1/60 of a second. Pressing the Clear key will reset the clock to all zeros. Figure 2 shows the contents of location 5 and representative times in seconds and minutes for a few number combinations.

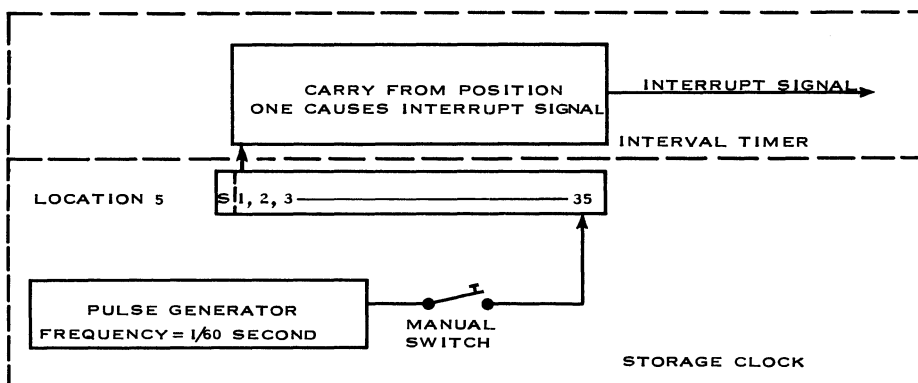

Figure 1. Schematic, Storage Clock and Interval Timer.

NOTE: Availability of this feature can be determined by requesting a price quotation from IBM. Copies of the bulletin are available only from IBM Region Sales Engineering Departments.

INTERVAL TIMER, STORAGE

This feature may be added to the storage clock and causes a program trap when a carry out of position 1 of location 5 is generated as a result of incrementation. This trap will store the contents of the instruction counter in location 6 and then execute the instruction at location 7, which will normally be a transfer instruction. If the instruction at location 7 does not modify the instruction counter contents, instruction execution will resume from the location, plus one, at which the trap occurred.

Traps, when signalled, will occur between instructions, but not while the central processing unit is hung up on an input-output select instruction or in manual status. They will be delayed until the following instructions are completed:

1. First instruction following an I-O Select instruction.
2. First instruction following a restore-channel-trap or an enable instruction.
3. First instruction following an execute instruction.

The timer is started by storing the 2's complement of the desired time interval in location 5 (expressed as a multiple of 1/60 second increments). The trap may be prevented by storing the 2's complement of the maximum interval (zeros = an interval of approximately 18.2 years).

<u>Octal Number in Location 5</u>	<u>Representative Number in Time</u>
1	.0166 seconds
2	.0333 seconds
3	.0500 seconds
4	.0666 seconds
5	.0833 seconds
10	.1333 seconds
100	1.066 seconds
500	5.333 seconds
1000	8.533 seconds
5000	42.66 seconds
10000	68.26 seconds or 1.134 minutes
50000	341.3 seconds or 56.88 minutes
3777777777 (maximum)	18.2 years

Figure 2. Location 5 Contents Conversion

