

# Synchronization in Timestamp-Based Cache Coherence Protocols

by

Quan Minh Nguyen

B.S., University of California, Berkeley (2014)

Submitted to the Department of  
Electrical Engineering and Computer Science  
in partial fulfillment of the requirements for the degree of

Master of Science in Electrical Engineering and Computer Science

at the

MASSACHUSETTS INSTITUTE OF TECHNOLOGY

June 2016

© Massachusetts Institute of Technology 2016. All rights reserved.

Author .....  
Department of Electrical Engineering and Computer Science  
May 20, 2016

Certified by .....  
Srinivas Devadas  
Professor of Electrical Engineering and Computer Science  
Thesis Supervisor

Accepted by .....  
Professor Leslie A. Kolodziejcki  
Chair, Department Committee on Graduate Students



# Synchronization in Timestamp-Based Cache Coherence Protocols

by

Quan Minh Nguyen

Submitted to the Department of Electrical Engineering and Computer Science  
on May 20, 2016, in partial fulfillment of the  
requirements for the degree of  
Master of Science in Electrical Engineering and Computer Science

## Abstract

Supporting computationally demanding workloads into the future requires that multiprocessor systems support hundreds or thousands of cores. A cache coherence protocol manages the memory cached by these many cores, but the storage overhead required by existing directory-based protocols to track coherence state scales poorly as the number of cores increases. The Tardis cache coherence protocol uses timestamps to avoid these scalability problems. We build a cycle-level multicore simulator that implements a version of the Tardis protocol that uses release consistency. Changing the coherence protocol, which affects what memory values a processor can observe, changes inter-processor communication and synchronization, two processes crucial to the operation of a multicore system. We construct Tardis versions of synchronization primitives and the atomic instructions they use, and compare them to their analogous implementations on a directory-based cache coherent multicore system. Simulations on several benchmarks suggest that the Tardis system performs just as well as the baseline system while preserving the ability to scale systems to hundreds or thousands of cores.

Thesis Supervisor: Srinivas Devadas

Title: Professor of Electrical Engineering and Computer Science



## Acknowledgments

Before I begin, I'd like to take this opportunity to thank the people who have made this journey even remotely tractable. First, I would especially like to thank my adviser, Srini, for providing key insights and guidance in this project and so warmly welcoming me into the group two years ago. I am very grateful to Xiangyao, who has never wavered from answering my unrelenting stream of questions about Tardis. I aspire to emulate their contagious enthusiasm and wide-spanning knowledge. In addition to my lab mates, my friends here have made my stay at the Institute at least as much play as it is work; a heartfelt thank-you to Aaron, Fady, Lisa, Liz, Mehrdad, Michael, and Wendy, who have been by my side the entire time. I am tremendously grateful to Albert, Andrew, Krste, Stephen, and Yunsup of the ParLab and ASPIRE Lab at Berkeley for intellectually launching me into the place where I am today. And, finally, I want to thank my family: my mother, father, and sister (better known to me as *Má*, *Ba*, and *Uyên*), for making it all possible. Just thinking of you and the love you have shown me is always a source of inspiration and hope.



# Contents

|          |  |           |
|----------|--|-----------|
| <b>1</b> | <b>Introduction</b>                                | <b>13</b> |
| <b>2</b> | <b>Timestamp-Based Cache Coherence Protocols</b>   | <b>17</b> |
| 2.1      | The Tardis Cache Coherence Protocol . . . . .      | 17        |
| 2.1.1    | Timestamps . . . . .                               | 19        |
| 2.1.2    | Reading Cache Blocks with Leases . . . . .         | 22        |
| 2.1.3    | Writing Cache Blocks through Time Travel . . . . . | 23        |
| 2.1.4    | Renewals . . . . .                                 | 24        |
| 2.1.5    | Per-Program Timestamps . . . . .                   | 25        |
| 2.1.6    | Main Memory, Incoherent Memory, and I/O . . . . .  | 27        |
| 2.2      | Release Consistency and RISC-V . . . . .           | 28        |
| 2.2.1    | Fences . . . . .                                   | 29        |
| 2.2.2    | Release and Acquire Instructions . . . . .         | 31        |
| 2.3      | Release Consistency Support for Tardis . . . . .   | 31        |
| 2.3.1    | Compact Timestamp Configurations . . . . .         | 32        |
| 2.3.2    | Cache Transactions . . . . .                       | 34        |
| 2.3.3    | Leases and Renewals in Tardis-RC . . . . .         | 37        |
| 2.4      | Stale Reads . . . . .                              | 37        |
| 2.5      | Techniques for Writing Tardis Programs . . . . .   | 40        |
| 2.6      | Previous Use of Timestamps for Coherence . . . . . | 41        |
| <b>3</b> | <b>Atomic Instructions</b>                         | <b>43</b> |
| 3.1      | Compare-and-Swap . . . . .                         | 43        |

|          |   |           |
|----------|---|-----------|
| 3.2      | Load-Reserved and Store-Conditional . . . . . | 45        |
| 3.3      | Atomic Memory Operations . . . . .            | 48        |
| <b>4</b> | <b>Synchronization</b>                        | <b>51</b> |
| 4.1      | Locks . . . . .                               | 51        |
| 4.1.1    | The Mellor-Crummey-Scott Queue Lock . . . . . | 53        |
| 4.2      | Barriers . . . . .                            | 54        |
| <b>5</b> | <b>Implementation</b>                         | <b>61</b> |
| 5.1      | Guiding Principles . . . . .                  | 61        |
| 5.2      | The RISC-V Rocket Microarchitecture . . . . . | 62        |
| 5.2.1    | Pipelining Timestamps . . . . .               | 62        |
| 5.2.2    | Extending the Memory Hierarchy . . . . .      | 63        |
| 5.3      | Network-on-Chip . . . . .                     | 64        |
| 5.3.1    | Manager/Client Abstraction . . . . .          | 64        |
| 5.3.2    | Network Topology . . . . .                    | 65        |
| <b>6</b> | <b>Evaluation</b>                             | <b>67</b> |
| 6.1      | Atomic Instructions . . . . .                 | 67        |
| 6.2      | Synchronization Primitives . . . . .          | 70        |
| 6.3      | Application Performance . . . . .             | 72        |
| <b>7</b> | <b>Conclusion</b>                             | <b>81</b> |
| 7.1      | Future Work . . . . .                         | 81        |
| 7.2      | Concluding Remarks . . . . .                  | 83        |



# List of Figures

|      |  |    |
|------|--|----|
| 2-1  | Simplified system diagram. . . . .   | 18 |
| 2-2  | Last-level cache metadata layout. . . . .  | 18 |
| 2-3  | Timeline diagram representing the validity of cache blocks within the Tardis protocol. . . . .       | 21 |
| 2-4  | Timeline diagram demonstrating a cache block read. . . . .   | 23 |
| 2-5  | Timeline diagram demonstrating a cache block write. . . . .  | 24 |
| 2-6  | Timeline diagram demonstrating a cache block renewal. . . . .  | 25 |
| 2-7  | Timeline diagram demonstrating interaction with main memory. . . . .                                 | 27 |
| 2-8  | Assembly code demonstrating a potential hit-under-miss situation a cache. . . . .                    | 28 |
| 2-9  | Timeline diagram demonstrating one of the limitations of Tardis with sequential consistency. . . . . | 29 |
| 2-10 | Timeline diagram demonstrating a write-read fence in Tardis. . . . .                                 | 30 |
| 2-11 | Timeline diagram demonstrating timestamps used in Tardis-RC. . . . .                                 | 33 |
| 2-12 | Example producer-consumer code. . . . .  | 38 |
| 2-13 | Using synchronization to communicate updated data through an external cache block. . . . .           | 40 |
| 3-1  | Hypothetical source code for a compare-and-swap instruction. . . . .                                 | 44 |
| 3-2  | Timeline diagram demonstrating avoidance of the ABA problem. . . . .                                 | 45 |
| 3-3  | Load-reserved/store-conditional instruction sequence. . . . .  | 45 |
| 3-4  | Timeline diagram demonstrating livelock freedom on the LR/SC instruction pair. . . . .               | 47 |

|     |   |    |
|-----|---|----|
| 4-1 | Source code for spin lock that uses compare-and-swap. . . . .                         | 52 |
| 4-2 | Diagram depicting linked-list nature of the MCS queue lock. . . . .                   | 54 |
| 4-3 | Source code for an implementation of the Mellor-Crummey-Scott queue lock. . . . .     | 55 |
| 4-4 | Timeline diagram illustrating the effects of a barrier in physiological time. . . . . | 56 |
| 4-5 | Source code for a sense-reversing barrier. . . . .                                    | 57 |
| 4-6 | Barrier exploiting the exclusive ownership state to notify other cores.               | 58 |
| 6-1 | Microbenchmark source code. . . . .   | 68 |
| 6-2 | Performance of the MCS queue lock microbenchmark. . . . .                             | 71 |
| 6-3 | Performance of a barrier microbenchmark. . . . .                                      | 72 |
| 6-4 | Performance of a vector-vector add benchmark exhibiting false sharing.                | 74 |
| 6-5 | Performance of a vector-vector addition benchmark without false sharing.              | 75 |
| 6-6 | Number of acquire messages sent on the TileLink networks. . . . .                     | 76 |
| 6-7 | Number of acquire messages sent on the TileLink networks. . . . .                     | 77 |
| 6-8 | Performance of a matrix-matrix multiplication. . . . .                                | 78 |

# List of Tables

|     |   |    |
|-----|---|----|
| 1-1 | Size and latencies of a computer’s memory hierarchy. . . . .  | 14 |
| 2-1 | Timestamps for Tardis-SC, a sequentially consistent version of Tardis.  | 21 |
| 2-2 | Timestamp update rules for the manager in the sequentially consistent version of the Tardis cache coherence protocol. . . . . | 26 |
| 2-3 | Timestamp update rules for the manager in the sequentially consistent version of the Tardis cache coherence protocol. . . . . | 26 |
| 2-4 | Message types used in Tardis. . . . .   | 26 |
| 2-5 | Timestamp update rules needed to support relaxed consistency memory models. . . . .   | 32 |
| 2-6 | Timestamps for Tardis-RC, a release-consistent version of Tardis, as implemented in this thesis. . . . .                      | 33 |
| 2-7 | Actions performed by the client in the Tardis cache coherence protocol.   | 35 |
| 2-8 | Actions performed by the manager in the Tardis cache coherence protocol.  | 36 |
| 2-9 | Guidelines for timestamps to be sent along with messages to the last-level cache during cache misses. . . . .                 | 37 |
| 5-1 | Logical networks in the TileLink coherence protocol abstraction. . . .  | 64 |
| 5-2 | Timestamps required in network messages for coherence in the Tardis protocol. . . . .   | 65 |
| 5-3 | Evaluation system configuration. . . . .  | 66 |
| 6-1 | Performance of the load-reserved/store-conditional microbenchmark. .  | 68 |
| 6-2 | Performance of the atomic memory operation microbenchmark. . . .  | 69 |



# Chapter 1

## Introduction

We must build multicore systems that scale well to hundreds or thousands of cores to run applications increasingly necessary for progress and discovery in modern society. These systems have become ubiquitous in everyday life, from mobile platforms to datacenter computers. Even systems with one microprocessor may have multiple cores running independently and in parallel. Computer architects have taken advantage of the falling cost of transistors and evolving circuit fabrication techniques to increase both the number of cores and the amount of memory on a single system.

Low-latency, high-throughput memory ensures that these applications run quickly. On a *shared-memory machine*, all cores access the same main memory. However, these cores rarely make changes directly to main memory – instead, they change the data stored in a *cache*. A cache contains small sections of frequently used memory to exploit spatial and temporal locality, and are essential in the design of high-performance computers. Nowadays, the computer’s *memory hierarchy* separates a processor’s registers from main memory with multiple levels of progressively larger caches. A processor’s registers, at the top of the hierarchy, are fast, but small; main memory, at the bottom of the hierarchy, is relatively slow, but large. By balancing the speed and size trade-offs, the memory hierarchy grants the illusion of a vast, fast memory [1]. Yet, programmers assume that any core may immediately observe the changes to memory made by another core. The *cache coherence* system, which implements a specific *cache coherence protocol*, communicates with the cores to keep cached data in a state

| Type                | Size      | Latency     |
|---------------------|-----------|-------------|
| Processor registers | 1000 B    | 300 ps      |
| L1 caches           | 64 KB     | 1 ns        |
| L2 caches           | 256 KB    | 3 – 10 ns   |
| Main memory         | 4 – 16 GB | 50 – 100 ns |

Table 1-1: Size and latencies of a computer’s memory hierarchy, from [1].

that a programmer can reason about.

Caches typically maintain data in equally-sized parcels known as *cache blocks*. Throughout the execution of a program, cache blocks move between levels of the memory hierarchy – from the expansive but slow main memory to the cache nearest the processor, the first-level (or “L1”) cache. The cache coherence protocol must ensure maximum memory throughput, so it must permit multiple cores to *share* the same area of memory. However, the protocol must also propagate any changes to memory to these caches so that the system stays coherent.

The prevailing method to ensure cache coherence today is the *directory protocol*. The directory manager, which resides at the outer levels of the cache hierarchy, maintains a list of all cores currently caching a cache block as a part of its *metadata*. At its simplest, the directory manager uses a bit vector with  $n$  bits, one for each core, to track who currently accesses a cache block, and a manager keeps a bit vector for each cache block. Before a core may write to a cache block, it must obtain *exclusive ownership* so that no other core may read stale data. To obtain exclusive ownership, the directory manager *invalidates* all copies of the cache block at all other cores. The manager scans this “full-map” bit vector and sends each core a message instructing it to no longer cache that area of memory. This scheme works well due to its simplicity and because the number of cores sharing a particular cache block, up until recently, has remained small.

However, the number of cores on a single die continues to rise, as does the number of processors in a shared-memory system. For instance, Intel’s second-generation Xeon Phi processors, code-named “Knights Landing”, boasts 72 cores with access to up to 384 GB of main memory [2]. A typical “full-map” directory, if implemented on this

system, would require 72 bits per cache block to represent all possible combinations of sharers. This amount of storage would represent more than 10% metadata overhead for a 64-byte cache block, and will only grow as the number of cores increases. Several techniques [3, 4, 5] reduce the cost of scaling the directory, but no technique suitably solves the problem of effectively broadcasting invalidation messages to all sharers.

Tardis, a *timestamp*-based cache coherence protocol, reduces the per-cache block metadata overhead from  $O(n)$  to  $O(\log n)$  in the number of sharers [6]. Instead of tracking all sharers of a cache block, the Tardis protocol only tracks its exclusive owner. To maintain coherence, the Tardis protocol also assigns each cache block a set of timestamps. Each core, which gains a timestamp counter in this protocol, may only read a cache block if it satisfies conditions on its counter and the cache block’s timestamps. The Tardis protocol, which provably preserves sequential consistency [7], opens the door to dramatically scaling the number of cores in a system by dispensing with excess metadata.

We wish to understand the effects of a system running Tardis to establish a case for future implementation in real-world systems. The first efforts at modeling the performance of the Tardis protocol were completed in Graphite, a functional simulator that only performs *lax synchronization*. In this model, cores are only synchronized when they interact on “true synchronization” events [8], making it possible for simulated events to occur out-of-order from when they would occur on a real system. However, synchronization is a necessary component of a parallel program running on a multicore machine. Furthermore, Graphite cannot faithfully model effects that arise from inter-processor communication, such as message latency and network contention, even while modeling the memory (“full” mode). These shortcomings prevent us from fully measuring and understanding Tardis, so we opt to model it with cycle-level simulation.

## Organization and Contributions of this Thesis

In this thesis, we study synchronization on a machine implementing the Tardis protocol on a cycle-level simulator in the interest of building it on a real platform, whether synthesized for a field-programmable gate array (FPGA) or for fabrication. We modify a version of Tardis that supports sequential consistency (“Tardis-SC”) to produce “Tardis-RC”, a version of Tardis that supports the *release consistency* memory model in Chapter 2. Using Tardis-RC, we define new semantics for atomic instructions and observe their impacts on synchronization primitives in Chapters 3 and 4. We implement a prototype cycle-level simulator in Chapter 5, the first known implementation of Tardis-RC with cycle-level detail. In Chapter 6, we demonstrate the performance of Tardis implementations of atomic instructions and synchronization primitives and their baseline counterparts on several benchmarks. We summarize our findings and discuss possibilities for future work in Chapter 7.



# Chapter 2

## Timestamp-Based Cache Coherence Protocols

In this chapter, we provide an overview of the Tardis cache coherence protocol. First, we introduce the sequentially consistent version of Tardis, Tardis-SC, as described in [6]. We specify Tardis-RC, a version of Tardis that supports release consistency, to match the architecture used in our cycle-level simulator. We also extend Tardis to memory-mapped devices and input/output (I/O).

### 2.1 The Tardis Cache Coherence Protocol

A system that implements the Tardis protocol has a number of cores and their caches connected by an on-chip network that is eventually serviced by a shared last-level cache, as typified in Figure 2-1. We refer to the system that maintains metadata at the last-level cache as the *manager*. *Clients*, such as a core's private data and instruction caches, communicate with the manager to receive cache blocks. Clients that may store modified blocks in a private cache are *cached clients*. Cached clients require invalidations, while *uncached clients* (for instance, memory-mapped I/O) do not. Tardis distinguishes itself from other cache coherence protocols because the manager stores *only* the identity of the exclusive owner of the cache block, if it exists, resulting in  $O(\log n)$  metadata storage per cache block. Consequently, the

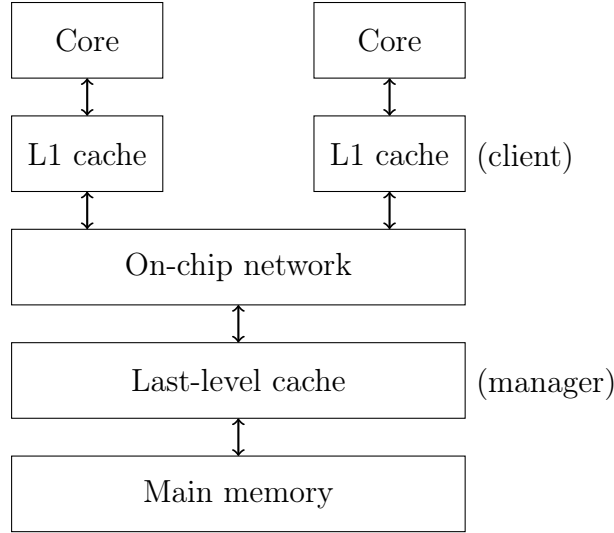

Figure 2-1: Simplified system diagram.

manager has no knowledge of the state of read-only cache blocks in the system. For these blocks, timestamps inform clients as to whether reading the block preserves the memory consistency guarantees of the system. The next several sections discuss the rules regarding these timestamps. Figure 2-2 depicts a possible layout of a cache block’s metadata at the manager. The size of the timestamps does not grow with the number of sharers, preserving scalability in systems with potentially hundreds or thousands of cores.

|         |       |       |            |            |            |
|---------|-------|-------|------------|------------|------------|
| Client  | State | Tag   | <i>wts</i> | <i>rts</i> |            |
| Manager | State | Owner | Tag        | <i>wts</i> | <i>rts</i> |

Figure 2-2: The potential layout of cache block metadata at the client (for example, an L1 data cache) and the manager (for example, a last-level cache).

As in an ordinary directory-based protocol, any cache block may be read by any client. The permissible operations on a cache block at the client are tracked with states identical to a typical directory protocol, such as MESI [9]. We use these protocol states for the rest of the thesis.

## Time

The definition of “time” plays an important role in the Tardis protocol, so we take care to define it here<sup>1</sup>. *Physical time* is the time observed in accordance with natural phenomena; that is, wall-clock time. *Logical time*, perhaps most well-established as Lamport clocks, numbers events based on a monotonically increasing counter without regard to the passage of physical time [11]. Tardis combines both notions of time to form physical-logical time, shortened to *physiological time*<sup>2</sup>, to establish a global memory ordering between memory operations on cache blocks within a multiprocessor system. Thus, something said to occur at the same *physiological* time may have actually happened at two different *physical* times.

Memory models describe how the memory operations in a program (which defines the *program order*) may be interleaved to form a *global memory order*. The *sequential consistency* model stipulates that “the result of any execution is the same as if the operations of all the processors were executed in some sequential order, and the operations of each individual processor appear in this sequence in the order specified by its program” [12]. The physiological time rule of Tardis-SC [6] establishes a global memory order with timestamps assigned to memory operations:

**Definition 1** (Physiological time rule). *For an operation  $X$  to occur before  $Y$  in the global memory order,  $X$ 's timestamp must be ordered before  $Y$ 's timestamp, or if they have the same timestamp, that  $X$  must be ordered before  $Y$  in the program.*

### 2.1.1 Timestamps

The Tardis protocol assigns a *write timestamp* and a *read timestamp* to each cache block, which we denote as *wts* and *rts* respectively. These timestamps do not correspond to any actual operation, but instead specify which physiological times a memory operation may occur. In Tardis-SC, the sequentially consistent version of the Tardis protocol, each client keeps a timestamp counter to track its own sense of

---

<sup>1</sup>More precisely than “a big ball of wibbly wobbly timey wimey stuff.” [10]

<sup>2</sup>Physiological time has no relation to the biological notion of physiology.

physiological time, which we denote as  $pts$ .<sup>3</sup> To satisfy the protocol’s requirement for totally ordered timestamps, we represent physiological timestamps with integers. In practice, 64-bit unsigned integers suffice and will never roll over in human-fathomable timescales. A client can store  $pts$  in a register, while caches at the client and manager can store  $wts$  and  $rts$  in a cache metadata array.

The write timestamp  $wts$  and the read timestamp  $rts$  denote the minimum and maximum physiological times at which the cache block data assigned those timestamps are considered valid. To have valid cache block data, the read timestamp must be no less than the write timestamp; that is,  $wts \leq rts$ . In Section 2.1.2, we will restrict reads to the cache block to clients that have a  $pts$  that fall within this range. The validity of a cache block can then be expressed as an integer interval, which we denote in this thesis as  $[wts, rts]$ , emulating the notation for real-valued intervals that contain both the start and end values. The Tardis protocol stipulates a crucial invariant for these timestamps which we term the *Tardis invariant*:

**Definition 2** (Tardis invariant). *For a specific cache block, only one version of its data may exist in a given timestamp interval  $[wts, rts]$ .*

Figure 2-3 depicts the validity of a cache block on a timeline. In this figure, physiological time increases to the right. The cache block’s data,  $d$ , are valid in the interval  $[5, 9]$ . Reads to the cache block occurring at timestamps before 5 or after 9 may yield different data different from  $d$ .

An immediate consequence of this invariant is that changes to the data always generate a new pair of timestamps with an interval disjoint from that of the old data. A more subtle implication is that the value of  $rts$  may be increased as long as the data in the cache block do not change. Increasing the  $rts$  of a cache block amounts to “renewing“ a cache block. Renewals, covered in Section 2.1.4, allow clients to extend the range of physiological times they may read the data. The Tardis invariant helps programmers and computer architects reason about the function of the protocol. For

---

<sup>3</sup>The term *processor timestamp* gives rise to the abbreviation  $pts$ , but such a timestamp applies to any caching client.

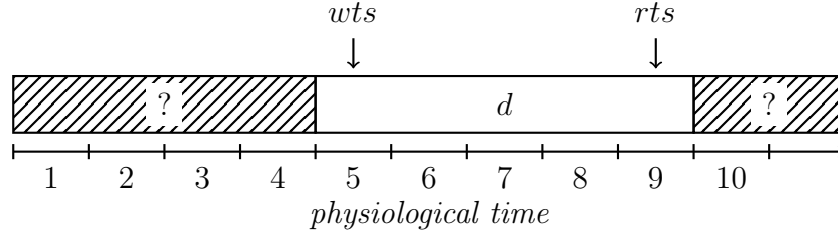

Figure 2-3: Timeline diagram representing the validity of a cache block. Physiological time increases to the right, and all timestamps are integers. Rectangles on the same row refer to the same cache block, and the text enclosed refers to the data. The smallest integer a rectangle overlaps represents that cache block’s *wts*; the largest integer represents that cache block’s *rts*. We use a hatched pattern to emphasize that the data outside *wts* and *rts* may not be known to the client.

instance, in Chapter 3 we demonstrate that the Tardis invariant can mitigate the ABA problem for the compare-and-swap atomic instruction.

A client’s *pts* may only *increase*; however, *pts* only changes when the client interacts with memory – *pts* does not increase with wall-clock time or the cycle count. Reading memory may not alter a client’s *pts* at all. With a single timestamp, a caching client can maintain sequential consistency; the next several sections review Tardis-SC as specified in [6]. Physiological timestamps exist for *uncached* regions of memory as well; they are discussed in Section 2.1.6. We summarize the timestamps discussed so far, and their function, in Table 2-1.

| Name       | Purpose  |
|------------|--|
| <i>pts</i> | Tracks a client’s position in physiological time.  |
| <i>wts</i> | The physiological time for which the data assigned to this timestamp are valid.  |
| <i>rts</i> | At a client, the last physiological time for which the data assigned are valid. At the manager, the last time for <i>any</i> client. |

Table 2-1: Timestamps for Tardis-SC, a sequentially consistent version of Tardis.

## 2.1.2 Reading Cache Blocks with Leases

In the Tardis protocol, the manager *leases* cache blocks to clients by sending data and the timestamps indicating when the data are valid. The difference between *wts* and *rts* is the “length” of the lease, and it roughly corresponds to the number of intervening memory operations before the cache block must be *renewed*, discussed in Section 2.1.4. At the last-level cache, the *wts* of a cache block represents the timestamp of the most recent store. The *rts* of a cache block represents the last physiological time for which the data currently stored in the cache block are valid. To request a read-only copy of the cache block, a client sends its *pts* to the manager. The manager advances the *rts* its cache block as prescribed in Equation (2-1).

$$rts \leftarrow \max \begin{cases} wts + \text{lease} \\ rts \\ pts + \text{lease} \end{cases} \quad (2-1)$$

At minimum, we add the lease value to the block’s current *wts* (line 1). If the cache block has been leased to another core, the manager will have already updated *rts*; we ensure that *rts* never decreases (line 2). Finally, in cases where *pts* far exceeds the other two values, we ensure that the lease will be valid for the core by including *pts* in the lease computation (line 3). The write timestamp (*wts*) does not change in computing the lease. Along with the cache block data, the last-level cache sends the *wts* and updated *rts* to the sharer.

If the cache block’s *wts* exceeds *pts*, the client advances its *pts* to at least *wts* to satisfy the Tardis invariant. Advancing *pts* causes the core to “travel through time,” possibly changing the data it may read from other cache blocks. Figure 2-4 demonstrates a read performed by the client.

Suppose that a cache block is valid from timestamps [5, 9]. If a client’s *pts* is 0, and it reads the cache block, it advances its *pts* to at least *wts* – in this case, 5 – to observe data *d*. We exploit Tardis’s ability to “jump” forward in time to also write cache blocks.

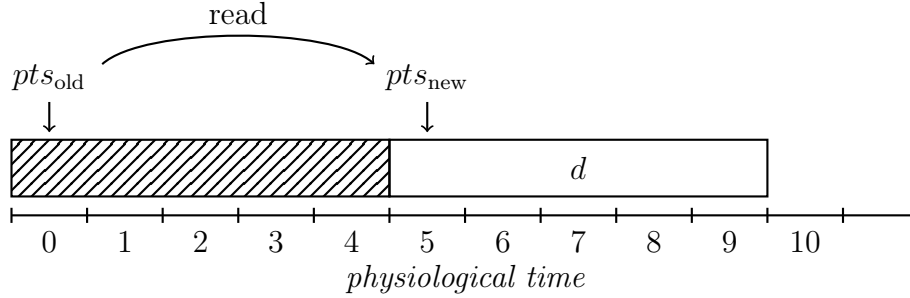

Figure 2-4: Reading from a cache block. Because  $pts < wts$ , we advance  $pts$  to at least  $wts$  to read the cache block’s data.

### 2.1.3 Writing Cache Blocks through Time Travel

Clients must request exclusive ownership of a cache block to modify its data. If another client exclusively owns that cache block, the manager issues a writeback request to that client before granting the original requester the exclusively-owned cache block. In the directory protocol, the manager must also invalidate all read-only copies of the cache block. In Tardis, *invalidations of read-only copies of the cache block are not necessary*. To grant exclusive ownership of a cache block, the manager sends its values of  $wts$  and  $rts$  for that cache block to the requester. Because  $rts$  represents the last physiological time at which a client may read the current version of that cache block, the earliest timestamp at which the data may change is  $rts + 1$ . The client “jumps” to this physiological time to modify the data, thus lending the protocol its name. Figure 2-5 demonstrates a write operation.

Equation 2-2 describes the update process for  $wts$  when a client writes to a cache block:

$$wts \leftarrow \max \begin{cases} rts + 1 \\ pts \end{cases} \quad (2-2)$$

When a client writes to its exclusively-owned copy of a cache block, it modifies the timestamps of its local copy with no need to notify the timestamp manager. When writing to a cache block, the client must advance  $wts$  to at least  $rts + 1$  (line 1). However,  $wts$  must also be at least the value of  $pts$  (line 2). To preserve the Tardis

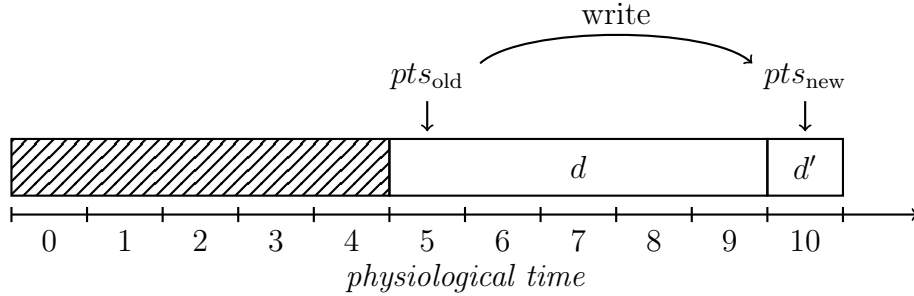

Figure 2-5: Writing a cache block. We advance  $pts$  past the  $rts$  of the cache block containing  $d$  to write  $d'$ .

invariant, we also advance  $pts$  and  $rts$  to the updated  $wts$ .

Suppose a client has permissions to write to a cache block that is currently valid from timestamps  $[5, 9]$ , and its  $pts$  is 5. When it performs a write, the client advances the timestamps of its local copy of the cache block to at least  $rts + 1$ , which is 10, and also advances its  $pts$  to that point as well. At timestamp 10, it writes new data to the cache block,  $d'$ , overwriting the cache block originally storing  $d$ .

This makes it possible for two cores to cache the same region of memory but have different data in the cache blocks. However, these cache blocks will have disjoint timestamp intervals. To make space for another cache block, clients may have to *evict* cache blocks. For read-only blocks, clients in the Tardis protocol may simply clear them to evict them. In a conventional directory-based protocol, the client would have to notify the manager of the cache eviction for bookkeeping. If they evict exclusively-owned cache blocks, clients must return the (possibly) modified data to the last-level cache.

### 2.1.4 Renewals

Clients advance their timestamp counters whenever they modify cache blocks. A cache block *expires* at a client when the client's  $pts$  exceeds the  $rts$  of that cache block. The cache block's data may have changed beginning at timestamp  $rts + 1$ , so the client must learn whether the cache block has changed by sending a *renewal* request to the manager. The manager compares the  $wts$  of the request to the  $wts$



of the cache block stored at the manager to discern whether the cache block has changed. If they do not differ, the renewal succeeds, and the manager advances the *rts* of the cache block at the manager to contain at least the client's *pts*, also sent with the renewal message. The manager completes the renewal process by informing the client of the cache block's *rts*, and no cache block data transfer is needed. If the data have changed at the manager, the manager sends the client the modified data alongside the updated timestamps as if it were an ordinary cache block read request. Figure 2-6 demonstrates the renewal process.

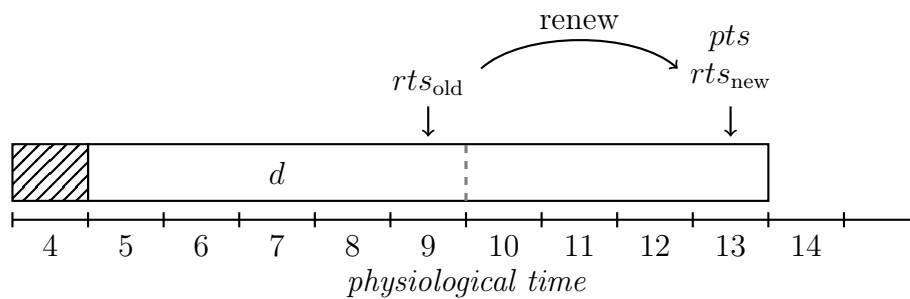

Figure 2-6: Renewing a cache block. Because  $pts > rts_{old}$ , we must renew the cache block to make sure it has not changed by the time we read it at timestamp  $pts$ .

In this case, the cache block is valid from timestamps 5 to 9, but  $pts$  is 13. The client sends a renewal request to the manager with the cache block's *wts* and the client's  $pts$ . If  $wts = 5$  at the manager, the data has not changed; the manager extends *rts* to at least  $pts$ , and sends the new *rts* – in this case, 13 – to the client. If the data have changed, it sends the data and a new set of timestamps. Tables 2-2 and 2-3 summarize the key timestamp update rules for Tardis-SC. Table 2-4 details the messages used in the Tardis protocol.

### 2.1.5 Per-Program Timestamps

Programs that do not interact through shared memory should maintain disparate sets of timestamps to prevent memory operations in one program from prematurely expiring cache blocks in other programs. However, this tasks the operating system with saving and restoring timestamp state during a context switch. However, simpler

| Core event | Cache Block State      | Result     | Actions   |
|------------|------------------------|------------|---|
| L1 load    | Invalid                | Load miss  | Send SHARE request to L2  |
|            | Shared; $pts > rts$    | Load miss  | Send RENEW request to L2  |
|            | Shared; $pts \leq rts$ | Load hit   | $pts \leftarrow \max(pts, wts)$   |
|            | Exclusive              | Load hit   | $pts \leftarrow \max(pts, wts)$<br>$rts \leftarrow \max(pts, wts, rts)$ |
| L1 store   | Shared                 | Store miss | Send UPGRADE request to L2  |
|            | Exclusive              | Store hit  | $wts, rts, pts \leftarrow \max(rts + 1, pts)$                           |
| Eviction   | Shared                 |            | Silently drop cache block<br>State $\leftarrow$ Invalid                 |

Table 2-2: Timestamp update rules for the client in the sequentially consistent version of the Tardis cache coherence protocol. Only the key rules are listed; the reader is referred to [6] for the full table.

| Network event  | State     | Actions  |
|----------------|-----------|--|
| Any request    | Exclusive | Send owner WRITEBACK request   |
| SHARE request  | Shared    | $rts \leftarrow \max(wts + \text{lease}, pts + \text{lease}, rts)$<br>Send client SHARE response   |
| RENEW request  | Shared    | $rts \leftarrow \max(wts + \text{lease}, pts + \text{lease}, rts)$<br>If $wts_{\text{request}} = wts$ , send client RENEW response<br>else send SHARE response |
| MODIFY request | Shared    | Owner $\leftarrow$ requestor<br>State $\leftarrow$ Exclusive<br>Send requestor MODIFY response   |

Table 2-3: Timestamp update rules for the manager in the sequentially consistent version of the Tardis cache coherence protocol. Only the key rules are listed; the reader is referred to [6] for the full table.

| Message   | Purpose  | Timestamps |
|-----------|--|------------|
| SHARE     | Read a cache block                               | $pts$      |
| MODIFY    | Read or write a cache block                      |            |
| RENEW     | Extend a lease of a currently shared cache block | $pts, wts$ |
| UPGRADE   | Request permission to write a cache block        | $wts$      |
| WRITEBACK | Cede write permission; maybe write back data     | $wts, rts$ |

Table 2-4: Descriptions of basic messages in the Tardis cache coherence protocol. Clients send SHARE, MODIFY, RENEW, and UPGRADE requests, while they send WRITEBACK responses.

systems running only a single program will not incur performance penalties, as there is no context switching.

### 2.1.6 Main Memory, Incoherent Memory, and I/O

At system reset, no cache blocks are valid. Accesses to main memory bring cache blocks to the last-level cache, but Tardis does not propagate timestamps to main memory. In [6], the timestamp  $mts$  tracks accesses to main memory. For congruence with our existing timestamps, we split  $mts$  into  $wts_{\text{memory}}$  and  $rts_{\text{memory}}$ , which respectively represent the highest  $wts$  and  $rts$  of any cache block written back to main memory. When a cache block is loaded from main memory, it assumes the timestamps  $wts_{\text{memory}}$  and  $rts_{\text{memory}}$ . Although it applies to *all* cache blocks brought in from main memory, this conservative measure preserves coherence with a minimum of additional hardware. Figure 2-7 demonstrates the effects of reading and writing from main memory.

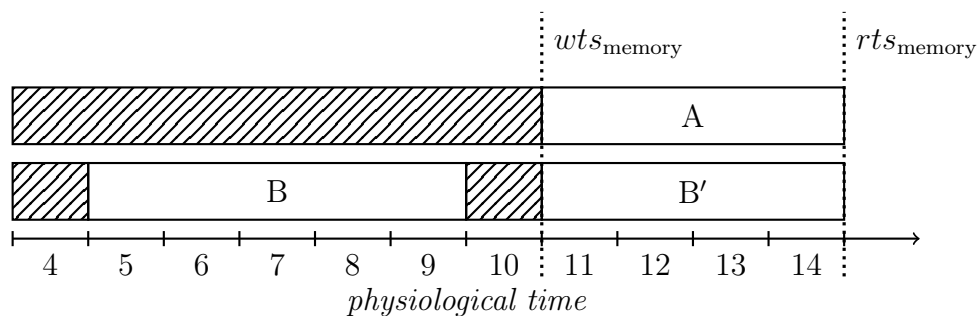

Figure 2-7: Interacting with main memory. When cache block A is written to main memory, it moves  $wts_{\text{memory}}$  and  $rts_{\text{memory}}$ . Any blocks read from main memory take timestamps  $wts_{\text{memory}}$  and  $rts_{\text{memory}}$ , even if their original  $wts$  and  $rts$  are smaller.

If the manager evicts cache block A to main memory, it adjusts  $wts_{\text{memory}}$  and  $rts_{\text{memory}}$ . If the manager then evicts cache block B to main memory, it does not adjust  $wts_{\text{memory}}$  or  $rts_{\text{memory}}$  because B's timestamps are smaller. However, if cache block B is brought back into the cache, denoted in the figure as B', it takes on timestamps  $[wts_{\text{memory}}, rts_{\text{memory}}]$ .

Timestamps that enforce a lower-bound on cache blocks' timestamps may be analogously applied to system input/output (I/O) operations, which, from the perspective

of the last-level cache, behave like accesses to main memory. Timestamps may be more generally applied to govern the interactions with data that comes from off-chip (“incoherent” memory).

## 2.2 Release Consistency and RISC-V

Sequentially consistent systems impose major limitations on program optimizations that reorder memory operations [13]. In fact, modern instruction set architectures do not implement full sequential consistency [14]. However, Tardis-SC inherits the limitations of sequentially-consistent computing. To demonstrate such a limitation, consider a processor connected to a decoupled non-blocking L1 data cache executing the instructions in Figure 2-8.

```

1 | ld x1, 0x0(x2) ; cache miss
2 | ld x3, 0x0(x4) ; cache hit

```

Figure 2-8: RISC-V assembly demonstrating a possible hit-under-miss situation, with registers `x2` and `x4` addressing separate cache blocks.

In Figure 2-8, the processor loads to `x1` from the address specified by `x2` and then to `x3` from the address specified by `x4`. Suppose that the first instruction triggers a cache miss while `x3` is a cache hit. Sequential consistency requires operations to complete in program order [12]. However, if the two memory locations are not causally associated, we unnecessarily wait for `x1`. An ordinary non-blocking data cache would be able to supply the value of `x3` to the processor for further computation.

In the Tardis protocol, if the block containing the data for `x3` contains timestamps  $wts_2$  and  $rts_2$  that happen to be greater than  $pts$ , the processor timestamp must be advanced to a value within the range  $[wts_2, rts_2]$ . Even worse, reading `x1` may cause the premature expiration of the cache block containing the data to be stored in `x3`, as shown in Figure 2-9.

If the cache block addressed by `x2` returns with a timestamp range  $[wts_1, rts_1]$  less than the now-updated  $pts$ , then the block must be renewed. In a relaxed consistency model, without an explicit fence instruction, renewals are not necessary – the

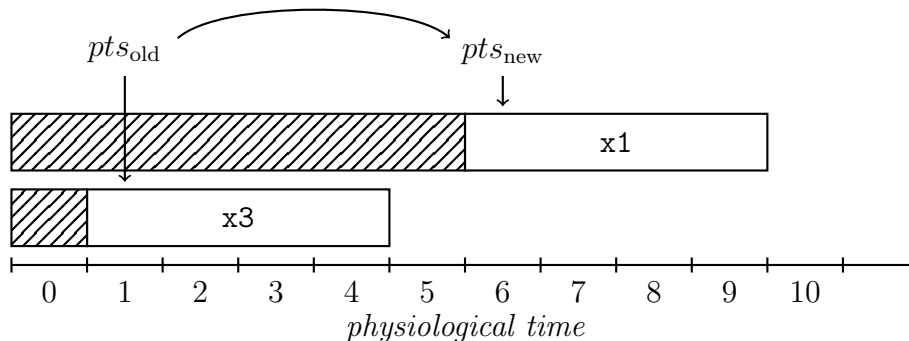

Figure 2-9: Timeline diagram demonstrating the limitations of Tardis with sequential consistency. By reading  $x1$ , the client expires the cache block storing  $x3$ .

processor can read the value  $x3$  without waiting for  $x1$ . These optimizations make a strong case for modifying Tardis to support release consistency.

In this thesis, we implement the Tardis cache coherence protocol on the Berkeley Rocket Chip [15] design, which implements RISC-V, a free, open-source ISA from the University of California, Berkeley [16]. Although no particular design choice compels the use of the RISC-V ISA or the release consistency memory model, the existing cycle-level simulator infrastructure for RISC-V is especially attractive for an elegant implementation of Tardis. Although our discussion focuses on release consistency as implemented in RISC-V, these techniques may of course be extended to other architectures.

A relaxed consistency memory model such as release consistency gives architectures the ability to aggressively reorder operations and trusts the programmers to insert fences as needed to preserve all true memory dependencies. In the following sections, we build Tardis-RC, a version of Tardis that implements the release consistency memory model.

### 2.2.1 Fences

A memory *fence* instruction preserves the ordering of memory operations as they appear in the program and how they actually apply to memory. Fences force all memory operations leading up to the fence (in the program) to be observable in

memory before proceeding to any memory operation in the program after the fence.

The RISC-V ISA provides a fine-grained fence instruction that specifies which types of memory operations the fence affects. Any memory operation in the *successor* set (in the program) may not be observed until all memory operations in the *predecessor* set (in the program) have been observed. Bits in the instruction encoding specify the members of the predecessor and successor sets, allowing arbitrary combinations of memory fences between reads, writes, inputs, and outputs. For instance, the fence instruction `fence w,r` prevents any read operation (`r`) from occurring until all writes (`w`) before the fence have been observed.

Memory fences in Tardis also have an additional stipulation: that memory operations occurring at physiological timestamps after the fence must occur after the most recent (in physiological time) memory operation. We can derive the physiological time requirements for the `fence w,r` instruction by examining the predecessor and successor sets: if we must prevent reads from happening before writes, we must require that read operations' timestamps be lower-bounded by any previous write operations' timestamps.

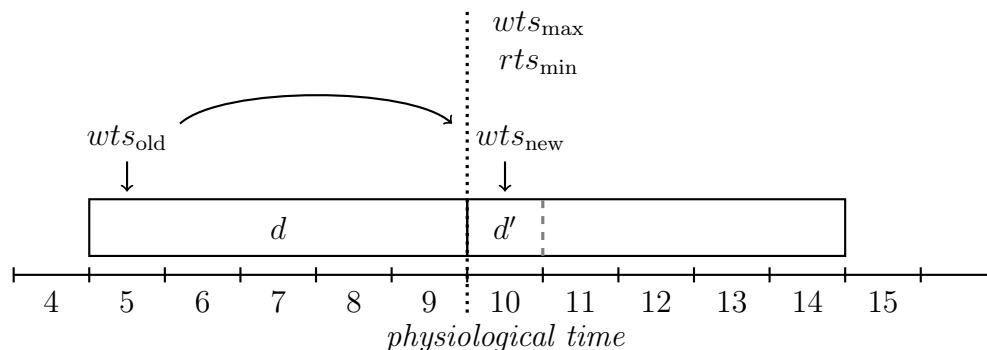

Figure 2-10: Using a write-read fence to prevent reads from happening before writes.

Figure 2-10 demonstrates the effects of a write-read fence. Suppose a client performs a write-read fence after overwriting  $d$  with  $d'$ . This fence means that any read operation occurring after the fence must occur after any write operation before the fence. Because the most recent write occurred at  $wts_{\text{new}}$ , at timestamp 10, no read operation (that is, no  $rts$ ) should fall below that timestamp. Therefore, we establish

a minimum read timestamp  $rts_{\min}$  that sets the lowest bound for a read at this client. After performing the fence, a client may read  $d'$ , but only at timestamps greater than 10. In this thesis, we only consider read/write fences, although we can extend our results to incorporate input/output memory fences.

## 2.2.2 Release and Acquire Instructions

Atomic instructions, described in greater detail in Chapter 3, modify memory with the guarantee that no other core interposes on these accesses – “indivisible” instructions. To support release consistency, the RISC-V ISA allows atomic instructions to encode that it represents an *acquire* or a *release* access. No memory operation after an *acquire* operation (in program order) can occur before the *acquire* operation (in memory order). Similarly, no memory operation before a *release* operation (in program order) can occur after the *release* operation (in memory order).

## 2.3 Release Consistency Support for Tardis

To fully relax memory operation ordering while supporting memory fences, we introduce additional timestamps. For arbitrary combinations of read/write memory fences, we need four new timestamps, which express *minimum* and *maximum* values for  $rts$  and  $wts$ , which we will term  $wts_{\min}$ ,  $rts_{\min}$ ,  $wts_{\max}$ , and  $rts_{\max}$ . The timestamps  $wts_{\min}$  and  $rts_{\min}$  express the earliest possible time at which memory operations can occur with respect to previous fences or acquire/release operations. The timestamps  $wts_{\max}$  and  $rts_{\max}$  express the earliest possible time at which the client may complete all of its memory operations. Unlike the minimum timestamps, the maximum timestamps do not enforce bounds; they merely track what values the  $wts_{\min}$  and  $rts_{\min}$  should be set to upon the next fence instruction. It is important to remark that the maximum timestamps required to observe all writes and reads are not necessarily set by the  $wts$  and  $rts$  of a particular cache block. If the operation may be observed at a timestamp less than  $wts_{\max}$  or  $rts_{\max}$ , then these timestamps do not change.

To support acquire and release atomic operations, we introduce a fifth timestamp,  $ts_{\text{rel}}$ , which tracks the timestamp at which a release operation occurred. The processor must guarantee that a release operation occurs after all preceding memory operations by ensuring store buffers have drained and all loads have been serviced. We also define an *acquire* timestamp,  $ts_{\text{acq}}$ , which expresses the time of the acquire operation following the most recent release operation. However, the acquire timestamp merely takes on the value of  $ts_{\text{rel}}$ . Thus, we can eliminate  $ts_{\text{acq}}$  by requiring that we check  $ts_{\text{rel}}$  whenever we must check  $wts_{\text{min}}$  or  $rts_{\text{min}}$ . We summarize the new rules for updating timestamps in Table 2-5.

| Operation         | Example Instruction    | Timestamp Update Rule   |
|-------------------|------------------------|---|
| Read-read fence   | <code>fence r,r</code> | $rts_{\text{min}} \leftarrow rts_{\text{max}}$                          |
| Write-write fence | <code>fence w,w</code> | $wts_{\text{min}} \leftarrow wts_{\text{max}}$                          |
| Write-read fence  | <code>fence w,r</code> | $rts_{\text{min}} \leftarrow wts_{\text{max}}$                          |
| Read-write fence  | <code>fence r,w</code> | $wts_{\text{min}} \leftarrow rts_{\text{max}}$                          |
| Acquire           | <code>lr.d.aq</code>   | Do nothing  |
| Release           | <code>sc.d.rl</code>   | $ts_{\text{rel}} \leftarrow \max(wts_{\text{max}}, rts_{\text{max}})$   |
| Load              | <code>ld</code>        | $rts_{\text{max}} \leftarrow \max(rts_{\text{max}}, ts_{\text{load}})$  |
| Store             | <code>sd</code>        | $wts_{\text{max}} \leftarrow \max(wts_{\text{max}}, ts_{\text{store}})$ |

Table 2-5: Rules for updating the timestamps needed to support relaxed consistency on RISC-V. Timestamps  $ts_{\text{load}}$  and  $ts_{\text{store}}$  represent the earliest physiological times at which a load or store may occur.

We no longer explicitly track the client’s place in physiological time with  $pts$ . Instead, we use a range of timestamps that bounds when memory operations may occur. Similarly, a load may happen as long as *some* part of the cache block’s timestamp interval extends past  $ts_{\text{min}}$ .

### 2.3.1 Compact Timestamp Configurations

Design constraints may limit timestamp storage, or the scheme we describe may be too fine-grained for the architecture and thus underutilized. To reduce the number of timestamps on the system, while preserving correctness, we must tighten constraints on when memory operations can occur. However, reducing the number of



timestamps may not impact performance if the architecture implementation, such as Rocket's, does not support the full breadth of memory operation orderings. We can merge  $wts_{\min}$  and  $rts_{\min}$  to create a timestamp  $ts_{\min}$  that contains the lowest possible timestamp at which *any* memory operation can occur. We can analogously create  $ts_{\max}$  by merging  $wts_{\max}$  and  $rts_{\max}$ .

| Name              | Purpose   |
|-------------------|---|
| $ts_{\min}$       | The earliest physiological time a client may read a cache block.  |
| $ts_{\max}$       | The earliest physiological time that allows a client to perform all memory operations thus far performed. |
| $ts_{\text{rel}}$ | The value of $ts_{\max}$ at the most recent release operation.  |

Table 2-6: Timestamps for Tardis-RC, a release-consistent version of Tardis, as implemented in this thesis.

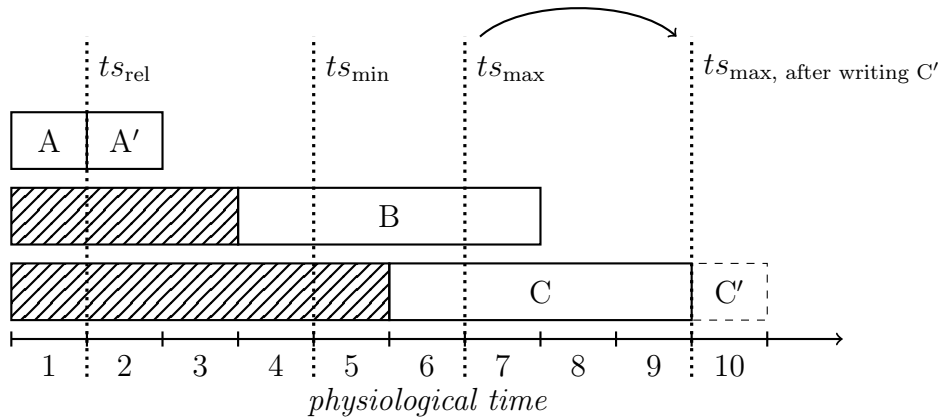

Figure 2-11: Timeline diagram representing timestamps used in Tardis-RC. A release operation sets  $ts_{\text{rel}}$ , and reads and writes may change  $ts_{\max}$ . Reads are valid only after  $ts_{\min}$ .

Figure 2-11 demonstrates the timestamps used in Tardis-RC. The timestamp  $ts_{\text{rel}}$  would be set to 2 if a release operation writes  $A'$ . No cache blocks need renewals as long as their validity exists at some point after  $ts_{\min}$ . Cache block B may be read at timestamps 5 through 7, but not at 4; cache block A must be renewed if the core

loses exclusive ownership after writing  $A'$ . The timestamp  $ts_{\min}$  may only be moved by a fence instruction – in the absence of fence instructions, clients may read cache blocks B and C in any order. If a client writes to cache block C, it would be written at timestamp 10;  $ts_{\max}$  would be set to 10 to express the highest timestamp of any operation performed by the client.

To conserve even more space, we can combine  $ts_{\min}$  and  $ts_{\text{rel}}$  into just one timestamp,  $ts_{\min/\text{rel}}$ . Such a timestamp would be adjusted on every release operation and fence.

### 2.3.2 Cache Transactions

Tables 2-7 and 2-8 specify the timestamp update rules for the relaxed consistency version of Tardis for the client and manager, respectively.

| Core event         | Cache Block State               | Result                           | Actions   |
|--------------------|---------------------------------|----------------------------------|---|
| L1 load            | Invalid                         | Load miss                        | Send SHARE request to L2  |
|                    | Shared and $ts_{\min} > rts$    | Load miss                        | Send RENEW request to L2  |
|                    | Shared and $ts_{\min} \leq rts$ | Load hit                         | $ts_{\max} \leftarrow \max(ts_{\min}, rts)$   |
|                    | Exclusive (clean or dirty)      | Load hit                         | $ts_{\max} \leftarrow \max(ts_{\min}, rts)$   |
| L1 store           | Invalid                         | Store miss                       | Send MODIFY request to L2   |
|                    | Shared                          | Store miss                       | Send UPGRADE request to L2  |
|                    | Exclusive (clean or dirty)      | Store hit                        | State $\leftarrow$ Exclusive (dirty)<br>$wts \leftarrow rts + 1$<br>$ts_{\max} \leftarrow \max(ts_{\min}, rts + 1)$ |
| Memory fence       |                                 | $ts_{\min} \leftarrow ts_{\max}$ |   |
| Eviction           | Shared                          |                                  | Silently drop cache block<br>State $\leftarrow$ Invalid   |
|                    | Exclusive (clean or dirty)      |                                  | Send WRITEBACK response to L2<br>State $\leftarrow$ Invalid   |
| WRITEBACK request  | Invalid or Shared               |                                  | Ignore  |
| WRITEBACK request  | Exclusive                       |                                  | $rts \leftarrow wts + \text{lease}$<br>Send WRITEBACK response to L2<br>State $\leftarrow$ Shared                   |
| Other L2 responses |                                 |                                  | Set cache block data and state<br>$[wts, rts]_{\text{data}} \leftarrow [wts, rts]_{\text{response}}$                |

Table 2-7: Actions performed by the client (the core and L1 cache). The possible protocol states mirror those in the standard MESI directory-based protocol, and the core maintains three timestamps:  $ts_{\min}$ ,  $ts_{\max}$ , and  $ts_{\text{rel}}$ . Without subscripts,  $wts$  and  $rts$  refer to the cache block stored at the client.

| Network event      | Cache Block State | Actions  |
|--------------------|-------------------|--|
| Any request        | Invalid           | Load from main memory<br>$wts \leftarrow wts_{\text{mem}}$<br>$rts \leftarrow \max(wts + \text{lease}, ts_{\text{request}} + \text{lease}, rts_{\text{mem}})$                |
|                    | Exclusive         | Send owner WRITEBACK request   |
| SHARE request      | Shared            | State $\leftarrow$ Shared<br>$rts \leftarrow \max(wts + \text{lease}, ts_{\text{request}} + \text{lease}, rts)$<br>Send client SHARE response                                |
| RENEW request      | Shared            | $rts \leftarrow \max(wts + \text{lease}, ts_{\text{request}} + \text{lease}, rts)$<br>If $wts_{\text{request}} = wts$ , send core RENEW response<br>else send SHARE response |
| MODIFY request     | Shared            | Owner $\leftarrow$ requestor<br>State $\leftarrow$ Exclusive<br>Send requestor MODIFY response   |
| WRITEBACK response |                   | Write back data<br>$[wts, rts]_{\text{data}} \leftarrow [wts, rts]_{\text{response}}$  |
| Eviction           | Shared            | $wts_{\text{mem}} \leftarrow \max(wts_{\text{mem}}, wts)$<br>$rts_{\text{mem}} \leftarrow \max(rts_{\text{mem}}, rts)$<br>Store to main memory                               |

Table 2-8: Actions performed by the manager (the last-level cache) in the Tardis cache coherence protocol, in response to actions performed by the core in Table 2-7. The last-level cache manages timestamps  $wts_{\text{mem}}$  and  $rts_{\text{mem}}$ , which are external to any cache block. Without subscripts,  $wts$  and  $rts$  refer to the cache block stored at the manager. Unlike the client, the manager has three cache block states: Invalid, Shared, and Exclusive.

In the event of a miss in the L1 data cache, the processor will need to request the missing cache block (if invalid) or renew it (if shared with an expired lease). No memory *load* can be observed at a time earlier than  $ts_{\text{rel}}$  or  $rts_{\text{min}}$ , so the timestamp sent to the timestamp manager should be  $\max(ts_{\text{rel}}, rts_{\text{min}})$  to ensure that the block can be read once it has been granted to the processor. Although a store may possibly return a new set of timestamps, the client may attempt an upgrade request to reduce network traffic, in which case it should send  $wts$ . Table 2-9 summarizes the timestamps sent with cache misses.

| Operation  | Action  |
|------------|---|
| Load miss  | $rts_{\text{message}} \leftarrow \max(ts_{\text{rel}}, rts_{\text{min}})$ |
| Store miss | $wts_{\text{message}} \leftarrow wts_{\text{data}}$                       |

Table 2-9: Guidelines for timestamps sent along with messages to the timestamp manager in the event of a cache miss.

### 2.3.3 Leases and Renewals in Tardis-RC

In Tardis-SC, the duration of the lease must balance the freshness of data and the number of renewals. Relaxed memory semantics explicitly permit cores to read stale values of the data, so it is not necessary to send a renewal request until absolutely necessitated by the rules in Table 2-7. Tardis-RC reduces the importance of fine-tuning the length of the lease, because renewals are only necessary when the core performs a release operation or memory fence.

## 2.4 Stale Reads

Tardis’s timestamps allow cores to remain consistent even if they cache stale data, but programmers occasionally require that a core eventually reads the *latest* value of a cache block. “Spinning” on a variable in memory, by repeatedly reading the same address in memory until its value changes, requires that the latest value eventually reaches the core. Conventional directory-based cache coherence protocols only permit

```

1 | static int x;
2 |
3 | void produce(int y)
4 | {
5 |     x = y;
6 | }
7 |
8 | int consume()
9 | {
10 |     return x;
11 | }

```

Figure 2-12: Example producer-consumer implementation in C.

readers of a cache block to observe the latest value. Before any core can update this value, the coherence manager invalidates all read-only copies of the cache block to avoid reading stale data. Unfortunately, a naïve implementation of Tardis may never return the latest value if nothing forces a client to contact the manager for the updated value. In this section, we explore stale reads and how to mitigate its problems.

Consider the producer-consumer example in Figure 2-12, and suppose that the producer code and consumer code run on separate cores. One core running the producer code writes integer `y` into a global variable `x`, and a separate core reads `x` using the consumer code. Programmers expect that all writes occurring to `x` will be visible to the consumer. In the directory protocol, this is enforced by cache invalidation; each time the producer writes to `x`, the coherence manager invalidates cores caching `x` before allowing modifications to the cache block.

In a naïve implementation of the Tardis protocol, no such invalidations enforce coherence for *loading* stale values. Thus, a consumer core already caching a read-only copy of `x` may never observe that the producer has written it, even if the producer has written back the data to the main memory.<sup>4</sup> If the consumer code spins on reading `x` without ever renewing the cache block, the consumer will never complete. To force cores in the Tardis protocol to read the latest value, computer architects must implement at least one of the following techniques below:

**Auto-incrementing timestamps** Cores periodically increment the minimum time-

---

<sup>4</sup>Issuing load requests against an invalid cache block will trigger a writeback to obtain a modified value.

stamp at which a core may observe data,  $ts_{\min}$ . Eventually,  $ts_{\min}$  exceeds the  $rts$  of the block and forces a renewal which produces the latest value. This is the method presented in [6].

**New instructions** A new instruction to force the processor to load the latest value, issuing a writeback to a core exclusively caching the cache block if necessary.

**Take exclusive ownership** A core obtaining the cache block in the exclusive state will always read the latest data.

**Synchronization** Using the above methods, a core can signal through a separate cache block that the data has changed. Using a memory fence, the core can observe the updated data.

Of the aforementioned techniques, automatically incrementing timestamps is one of the simplest *backwards-compatible* solutions. This technique does not require adding instructions to the ISA or program binary modifications, and will be essential for legacy code. The time between increments of  $ts_{\min}$  requires careful tuning. Too frequent increments will prematurely expire cache blocks, but too infrequent increments will cause long delays for programs that spin. As a result, this technique is particularly poorly suited for spin locks, which are normally regarded as the simplest solution for extremely short locking periods. Aggressively optimized architectures implementing Tardis may increment  $ts_{\min}$  when spinning on memory is detected.

It may be attractive to implement a new instruction that forces the processor to observe the latest value of the cache block. Such an instruction, however, would require the core to send a message to the last-level cache. Worse yet, a core spinning on a cache block, waiting for another core to update it, could flood the on-chip network. Furthermore, this requires modifications to the instruction set and the creation of a new network message, adding complexity to the hardware-software interface. We conclude that this is not an effective way to obtain the latest data in a cache block.

Finally, cores can obtain a fresh copy of the cache block by letting another core signal to it that the cache block has changed; that is, through synchronization. The

two cores maintain separate cache blocks. The “producer” uses one of the previously mentioned techniques (auto-incrementing timestamps, executing new instructions, or seizing exclusive ownership) to signal that data in the other cache block have changed. The “consumer” core performs a fence to observe the latest value. (The producer also performs a fence to ensure the data write completes before signalling the consumer.)

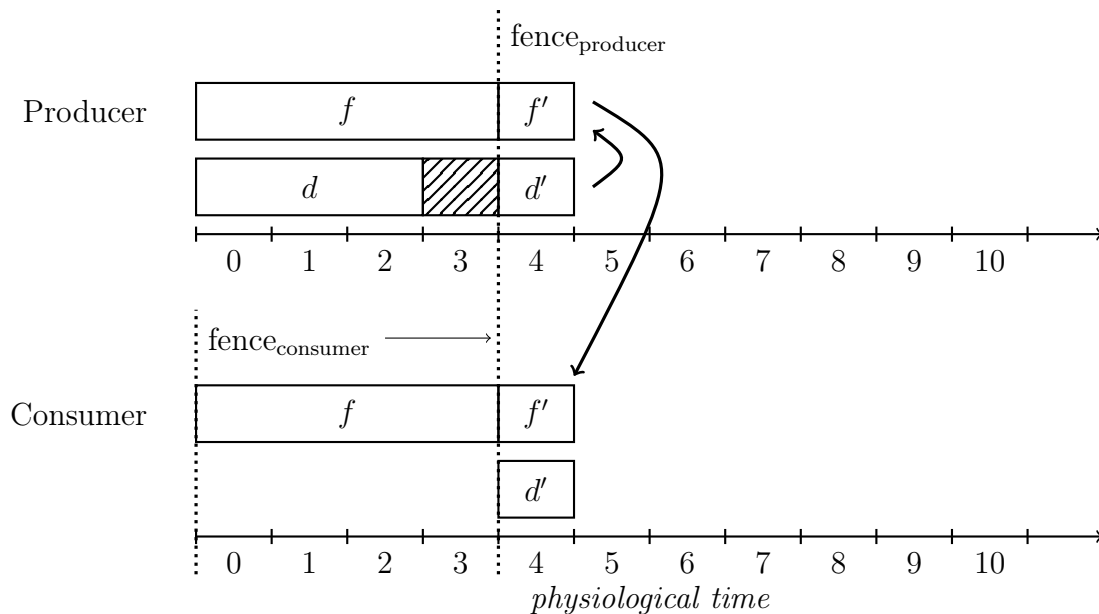

Figure 2-13: Timeline diagram demonstrating the use of synchronization to communicate updated data through an external cache block. The consumer uses load-latest instructions to maintain exclusive ownership of  $f$ , the flag. Once the producer writes  $f'$ , the consumer performs a fence to make sure that the read of  $d'$ , the new data, occurs after the read of  $f$ .

## 2.5 Techniques for Writing Tardis Programs

Programs written for systems that implement Tardis differ from conventional programs. Because Tardis may return the stale value of a cache block, programmers wishing to read the *latest* value must obtain the cache block in the exclusive state. On Rocket, the load-reserved instruction happens to load the cache block in the exclusive state, allowing us a way to read the latest data. We discuss the load-reserved instruction in greater depth in Chapter 3. Programs must avoid spinning, as they



may never make forward progress in the absence of auto-incrementing timestamps. Leveraging the exclusive state to implement synchronization sidesteps the problem of stale reads, as we will demonstrate in Chapter 4.

## 2.6 Previous Use of Timestamps for Coherence

Timestamps, including logical timestamps, are not new to coherent distributed shared systems. Lamport discussed logical time in what are now called Lamport clocks [11]. Vector clocks track shared data by assigning timestamps to each processor. The Ficus [17] and Bayou [18] systems tracked file version history with vector clocks and permitted disconnected operation. Treadmarks [19] also uses vector timestamps to manage distributed shared memory at the page level with a relaxed consistency model. However, each vector timestamp contains as many timestamps as there are processors in the system, so these schemes scale poorly to hundreds or thousands of cores.

Google’s Spanner system [20] distributes data across its datacenters using globally synchronized timestamps. Tardis does not require globally synchronized timestamps, and Spanner’s methods for ensuring consistency, including the use of atomic clocks, are excessive for the scale at which Tardis operates.

### Summary

In this chapter, we introduced the notion of physiological time and a sequentially consistent version of Tardis. With additional timestamps, we augmented Tardis to support a release consistency memory model as used in RISC-V, the ISA used by our simulator infrastructure. We discussed techniques to obtain the latest data in a cache block and how to write effective programs for Tardis. In the next chapter, we extend physiological time to atomic instructions.



# Chapter 3

## Atomic Instructions

Atomic instructions allow processor to modify memory without any other processor modifying the same part of memory. The name for these instructions arises from the notion that no other operation may “divide” these instructions. They are necessary in multiprocessor systems because ordinary loads and stores are not sufficient to perform synchronization [21].

Many types of atomic instructions exist, but some of the most well-known today include compare-and-swap (CAS), atomic memory operations (AMOs), and the load-reserved/store-conditional (LR/SC) pair. These instructions have usability trade-offs that make them suitable for some situations but not others. In this chapter, we take advantage of the Tardis invariant to implement new forms of commonly-used atomic instructions that eliminate some of the drawbacks affecting these instructions.

### 3.1 Compare-and-Swap

The compare-and-swap instruction has existed in the IBM System/370 [22] and in the x86 architecture since the Intel 486 [23]. The compare-and-swap (CAS) instruction compares a value in memory to one of the instruction’s operands; if so, the core switches the value in memory with another operand [22]. It returns the old value to the core. Invocations of compare-and-swap that fail the comparison do not affect memory.

```

1 | int compare_and_swap(int *m; int old, int val)
2 | {
3 |     if (*m == old) {
4 |         *m = val;
5 |         return old;
6 |     } else {
7 |         return val;
8 |     }
9 | }

```

Figure 3-1: Hypothetical source code for a compare-and-swap instruction that swaps `val` with the memory addressed by `m` if the old value matches `old`. The whole subroutine completes atomically.

The compare-and-swap instruction suffers from the ABA problem, in which clients are unable to detect changes to a memory location, even if the value has changed in the interim, because it has changed back to its original value [21]. A solution like double-word compare-and-swap increments a counter when it changes the data so that a second client reading from the memory will at least detect the change in the counter. Because Tardis associates data validity with the write timestamp, we can emulate the behavior of double-word compare-and-swap by reading the *wts* of the cache block to assure that the data has not changed. In fact, it is sufficient to only check *wts*! If any intervening writes have occurred, *wts* will change, due to the Tardis invariant. Figure 3-2 illustrates the utility of the Tardis invariant. Suppose a cache block initially starts with data A valid beginning  $wts_A$ . If B replaces A in a cache block, the write timestamp changes to  $wts_B$ . If A later replaces B, it also changes write timestamp, but to a value distinct from the first value of A,  $wts_{A'}$ .

Using Tardis’s timestamps allows us to differentiate cache block data and ameliorate the ABA problem affecting the compare-and-swap instruction. We employ the same technique to solve the livelock problem in the load-reserved/store-conditional instruction pair.

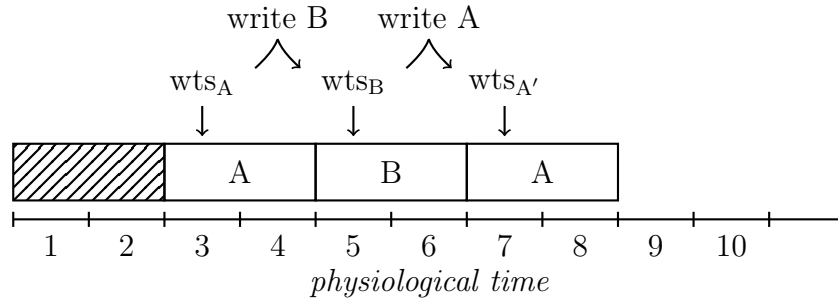

Figure 3-2: Timeline diagram demonstrating avoidance of the ABA problem on Tardis. Even though the data in intervals [3, 4] and [7, 8] are the same, a client can tell the cache block has changed because  $wts_A$  has changed to  $wts_{A'}$ .

### 3.2 Load-Reserved and Store-Conditional

The S-1 AAP multiprocessor introduced the load-reserved/store-conditional instruction pair [24]. The load-reserved/store-conditional (LR/SC) instruction pair allows critical, short computations to be made atomic by ensuring that no other processor changes the cache block between the load-reserved and store-conditional operations. If the reserved cache block is invalidated or otherwise modified, the store-conditional fails and indicates to the processor that it has failed, thus allowing the processor to try again. Figure 3-3 depicts a RISC-V assembly-language example of an instruction sequence using the LR/SC instruction pair.

```

1 | 1: lr.d x1, 0(x2)      ; set reservation
2 |   addi x1, x1, 1      ; critical section instruction(s)
3 |   sc.d x3, x1, 0(x2) ; write 0 into x3 if store succeeds, 1 otherwise
4 |   bnez x3, 1b        ; retry sequence if sc.d fails

```

Figure 3-3: RISC-V assembly demonstrating a typical load-reserved/store-conditional sequence that implements fetch-and-add.

Two cores executing the same LR/SC instruction sequence can create livelock by executing the load-reserved instruction at nearly the same (physical) time. Because this instruction strongly predicts a store-conditional instruction will follow, the manager grants the first core exclusive ownership. However, the second request forces the first core to write back its exclusively owned cache block in order to grant the second core exclusive ownership. The first core detects the cache block has changed,

and its store-conditional instruction fails. Livelock results from exclusive ownership ping-ponging between the two processors, never allowing one processor to successfully perform a store-conditional.

One solution to livelock requires delaying exclusive ownership requests [25]. The RISC-V ISA, for instance, requires that implementations guarantee the success of LR/SC sequences no longer than 16 instructions [16]. The L1 data cache on Rocket enforces this stipulation by preventing invalidations from reaching the data cache, even if they do not target the block addressed by the LR/SC pair. A store-conditional following a load-reserved in the Rocket core only fails if:

- the processor takes an interrupt or handles an exception,
- the address of the store-conditional does not match the address from the previous load-reserved, or
- more than 32 cycles have elapsed since the data cache processed the load-reserved instruction.

We observe that the last requirement is especially restrictive, because it prevents programmers from making modifications to data requiring more than 32 cycles to complete. As some instructions may stall, 32 cycles may not suffice to meet the ISA-mandated sixteen-instruction guarantee. This could result in programmers resorting to mutual exclusion locks to guard otherwise atomically modifiable memory, causing an increase in complexity and a reduction in performance.

Tardis can implement LR/SC functionality in a livelock-free manner by permitting cache blocks to exist in the shared state despite the presence of an exclusive owner. Typical implementations of the LR/SC pair use a “link register” that stores the address targeted by the load-reserved instruction to ensure that the store-conditional instruction targets the same address. In Figure 3-3, such a register would store the value of `x2`. In addition to the link register, Tardis maintains a register which we call  $wts_{lr}$  to store  $wts_{data}$ , the  $wts$  of the addressed cache block. When the cache performs the store-conditional operation, the L1 data cache gains exclusive ownership of the

block if it does not already have it. The data cache then checks  $wts_{lr}$  against the cache block's *current*  $wts_{data}$ . If  $wts_{lr} \neq wts_{data}$ , the store-conditional fails because the block has been written since it was load-reserved at this core. Otherwise, the timestamps match and the store-conditional succeeds, as no other core has written the block.

If an exclusive request to the manager causes this core to lose exclusive ownership of the cache block, the core retains  $wts_{lr}$  and the link register of the reservation. As long as  $wts_{data}$  does not change when we regain exclusive ownership of the original cache block, the store-conditional instruction can succeed. Note that the store-conditional instruction will still fail if the processor receives an interrupt or takes an exception. It will also fail if the store-conditional targets a different address from the one targeted by the load-reserved instruction. Most importantly, we no longer need the 32-cycle counter or a sixteen-instruction guarantee provided by the ISA. Now able to use nearly as many cycles as we need, we can design LR/SC sequences that modify the data in considerably more meaningful ways. Of course, keeping instruction sequences short will reduce the number of overlapping LR/SC sequences and keep the store-conditional failure rate low.

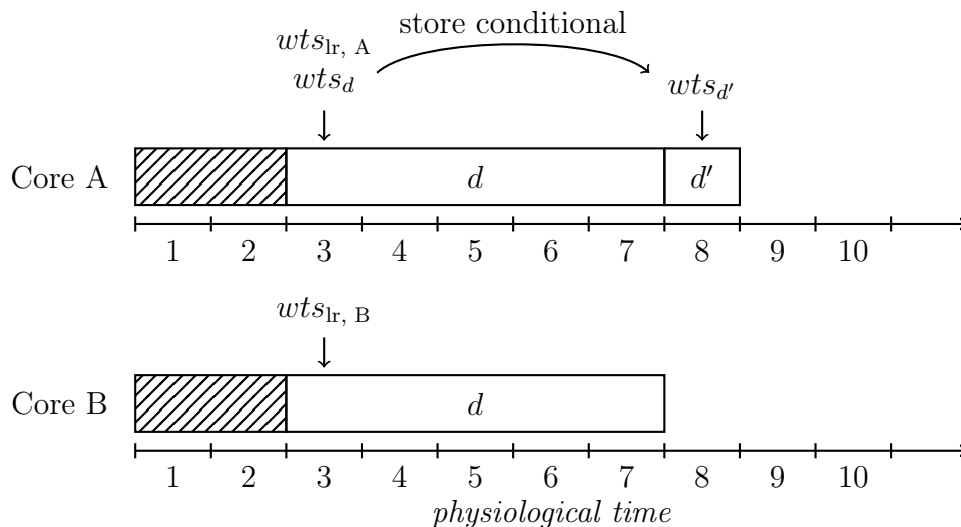

Figure 3-4: Timeline diagram demonstrating livelock freedom on the LR/SC instruction pair. Even if Core A loses exclusive ownership of  $d$ , it retains  $wts_{lr, A}$ . Upon regaining exclusive ownership, it can complete the store-conditional by verifying that it matches  $wts_{d'}$ .

Figure 3-4 shows an LR/SC instruction happening on a timeline diagram. Core A successfully writes  $d'$  because the  $wts$  of the cache block still matches the  $wts_{lr, A}$  saved by the load-reserved instruction. This implies that the cache block data has not changed. Upon gaining exclusive ownership, Core B will detect the altered  $wts$ , and fail the store-conditional instruction. This scheme elegantly avoids livelock because a cache block's  $wts$  persists through invalidations and only changes when a core changes the data at the cache block. Therefore, a write will eventually succeed at one of the cores.

### 3.3 Atomic Memory Operations

The NYU Ultracomputer introduced atomic memory operations (AMOs), described then as read-modify-write (RMW) instructions [26]. The Wisconsin Multicube architecture implemented hardware fetch-and-Phi (fetch-and- $\Phi$ ) operations [27]. These instructions write to memory the result of an operation with a register as one of its operands and the original value that memory location as the other. Phi ( $\Phi$ ) represents the operation – addition, bitwise AND, maximum, and so on – to be performed on the value in memory and a register operand. The cache returns the previous value of the memory location to the core.

In a system that supports *remote* AMOs, the manager uses its own arithmetic logic unit (ALU) to compute the result of an atomic memory operation. This approach eliminates the need to transfer cache block data, although the manager should ensure that no clients cache the block to reduce potential invalidations. *Local* atomic memory operations will require the cache block to be present at the L1 cache, and can be implemented by temporarily preventing cache invalidations.

When a remote AMO occurs on a system with a directory-based coherence protocol, it may have to invalidate current sharers. On a system that implements Tardis, AMOs do not need to invalidate sharers, reducing invalidation traffic. The last-level cache automatically updates  $wts$  and  $rts$  as if it were a client performing a store. An L1 data cache that implements local AMOs takes advantage of a cache block in the



exclusive state, and does not differ from the baseline implementation of AMOs.

## Summary

We gently altered three classes of atomic instructions to take advantage of physiological time. In doing so, we mitigated the ABA problem for the compare-and-swap instruction. With livelock freedom, we make the LR/SC instruction pair simpler to implement and easier to use. It could become feasible to modify larger data structures without excessive spinning. We also used physiological time to reduce cache block invalidations when performing remote AMOs. Fast, simple, and useful atomic instructions form the basis for constructing high-performance synchronization primitives, which we cover in the next chapter.



# Chapter 4

## Synchronization

Synchronization primitives ensure that concurrent programs work correctly by preventing unwanted concurrent accesses or by separating phases of computation. Many efforts have tried to improve the ability to scale synchronization on multicore machines [27, 28]. *Locks* prevent concurrent accesses to the same data by forcing serialization. *Barriers* allow separately running threads of execution to meet at a single point in physical time before proceeding onto the next phase of the program. We investigate the implementation of locks and barriers with the atomic instructions we built in Chapter 3. In this chapter, we refer to units executing parts of the same concurrent program as threads.

### 4.1 Locks

*Mutual exclusion* locks, or *mutexes*, prevent more than one thread from accessing a *critical section* of code – a section of code only one thread may execute at a time. Programmers want fast locks, so that threads contending for the lock do not take an excessive amount of time to acquire the lock. They also expect locks to work *fairly* – namely, if all threads that acquire the lock eventually release it, then all threads should pass through the critical section.

*Spin locks* are amongst the simplest of locks. A core acquires the lock by setting a lock bit, and unlocks it by clearing it. Figure 4-1 shows the source code for a spin lock

implemented with compare-and-swap. The variable `locked` contains 1 if it is locked and 0 if it is unlocked. The compare-and-swap instruction can be used to atomically acquire this lock by setting it to a non-zero value only if `locked` is not already 1. A core that receives a 0 from the `compare_and_swap` subroutine is the first core to swap in a 1, and may proceed into the critical section. To unlock the resource, the core with the lock writes 0 to `locked`. This lock is the test-and-set lock, named for the test-and-set (TAS) instruction, which compares and swaps only a single bit in memory [21].

```
1 | static int locked;
2 |
3 | void acquire_lock()
4 | {
5 |     while (compare_and_swap(&locked, 1) != 0);
6 | }
7 |
8 | void release_lock()
9 | {
10 |     locked = 0;
11 | }
```

Figure 4-1: Source code for a spin lock that uses compare-and-swap. The `compare_and_swap(m, v)` subroutine returns the previous value at the pointer `m` after swapping in `v`.

As `locked` resides in memory, other cores waiting to access the shared resource *spin* on the lock value by performing `compare_and_swap` until it successfully acquires the lock. This access pattern scales poorly, as multiple cores spin on the same cache block, only to be invalidated. What often results a *thundering herd* problem, in which a flood of processors attempt to acquire the lock simultaneously [29]. Some locks, like the test-and-test-and-set lock, alleviate the thundering herd problem by having cores spin on a local variable [21]. Despite their poor scaling, spin locks find use in applications with short waiting periods.

Tardis does not always supply the latest value of a cache block on an ordinary read, as discussed in Section 2.4. Furthermore, spin locks do not scale well [30]. Although no single lock algorithm performs well across all measures of speed, scaling, and complexity [28], we choose to analyze the Mellor-Crummey-Scott (MCS) queue

lock because it reduces the number of cache invalidations to one per lock release operation [31].

### 4.1.1 The Mellor-Crummey-Scott Queue Lock

The Mellor-Crummey-Scott (MCS) queue lock [30] forms a linked list of cores waiting to access a locked resource. Each core maintains its own *local* lock and knows the location of a *global lock* corresponding to that resource. The locks are queue nodes (*qnodes*), data structures that store the current locked state and the pointer to the next core waiting on the lock. Cores acquiring an already-locked lock append themselves to the tail of the linked list. The core with the lock releases the lock by writing to a field that allows the next core in the linked list to proceed. Figure 4-3 shows C code to acquire and release MCS locks. Because of its linked-list structure, and the way that each core unlocks the next, the MCS lock is well-suited to implementation on Tardis.

Figure 4-2 illustrates the basic operation of the MCS lock. Threads attempt to acquire the lock by performing a fetch-and-set operation (or atomic swap) with the global lock value, replacing it with a pointer to the thread's `my_lock` struct. If `global_lock` contained the null pointer, then the thread has successfully acquired the lock (step 2). If the pointer was not null, then the lock has already been acquired – the thread sets its own `locked` field to 1. Then, it sets the `next` field of the queue node at the end of the last node in the queue to point to its `my_lock` struct (step 3). A thread with the lock passes it to the next thread by following the `next` pointer to the next thread's `my_lock` struct and setting its `locked` field to 0 (step 4). (If it is the last thread in the queue, it sets `global_lock` back to the null pointer.)

The Tardis implementation of the MCS lock requires modifications to load the latest value of the `mcs_lock` struct members. In particular, the loops on lines 21 and 38 of Figure 4-3 must load the latest value of `locked` and `next`, respectively. We used the load-reserved instruction to obtain exclusive ownership to read the latest value.

1. Initially unlocked

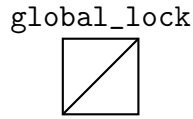

2. First lock by A

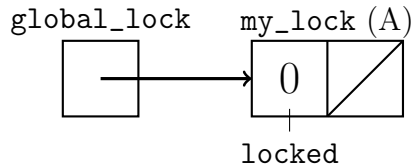

3. Second lock by B

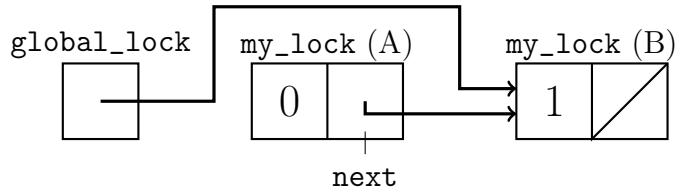

4. A unlocks B

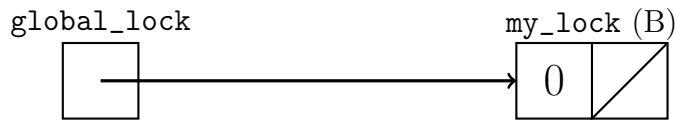

Figure 4-2: Diagram depicting the linked-list nature of the MCS queue lock. If a thread has taken `global_lock`, as A does in step 2, subsequent locking threads set the `locked` field of their copy of `my_lock` to 1, and append themselves to the end, changing `global_lock` to indicate where the next arriving thread should append its queue node.

## 4.2 Barriers

Barriers allow threads to synchronize their position in physical time before continuing. They also ensure that operations occurring before the barrier (in program order) have completed. Programmers can use barriers to make sure that straggling threads can catch up before moving onto the next phase of a computation. However, a barrier in Tardis must also synchronize threads in *physiological time*. We accomplish this with memory fences. Figure 4-4 demonstrates where threads must synchronize in physiological time.

```

1 struct mcs_lock {
2     struct mcs_lock *next;
3     int locked;
4 };
5
6 void acquire_lock(struct mcs_lock **global_lock, struct mcs_lock *my_lock)
7 {
8     struct mcs_lock *predecessor;
9
10    memory_fence();
11
12    my_lock->next = NULL;
13
14    predecessor = fetch_and_set(global_lock, my_lock);
15
16    if (predecessor) {
17        my_lock->locked = 1;
18        predecessor->next = my_lock;
19
20        /* wait for predecessor to unlock me */
21        while (my_lock->locked);
22    }
23
24    memory_fence();
25 }
26
27 void release_lock(struct mcs_lock **global_lock, struct mcs_lock *my_lock)
28 {
29    memory_fence();
30
31    if (!my_lock->next) {
32        /* if nobody follows me, try to clear global_lock */
33        if (compare_and_swap(global_lock, my_lock, NULL))
34            return;
35
36        /* a slow thread has set its locked field but not
37         * yet updated my_lock->next, wait for it to be set */
38        while (!my_lock->next);
39    }
40
41    my_lock->next->locked = 0;
42
43    memory_fence();
44 }

```

Figure 4-3: Source code for an implementation of the Mellor-Crummey-Scott queue lock.

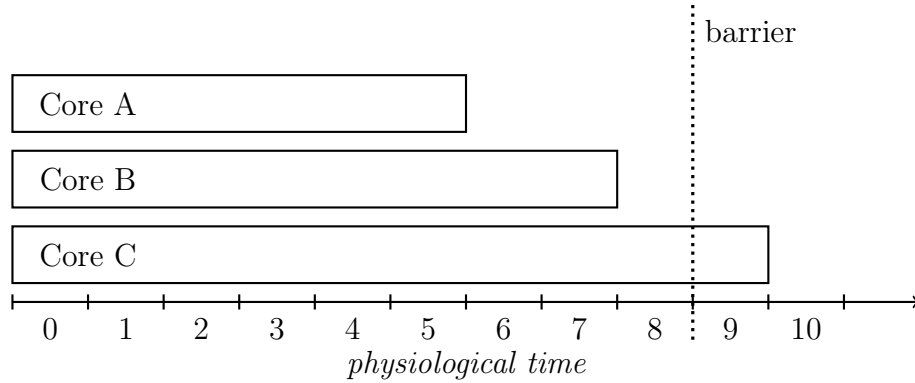

Figure 4-4: Timeline diagram demonstrating where threads must be after a barrier in physiological time. Rectangles represent the collective intervals of all memory operations performed by Cores A, B, and C. A barrier must allow Cores A and B to observe Core C’s operations.

Barriers typically count how many threads have arrived. All threads but the last thread begin spinning on a shared cache block value. The last thread to arrive at the barrier writes to the shared cache block, invalidating all shared copies and allowing the threads to leave the barrier.

Barriers that rely on the update of a shared variable assume that threads quickly learn the most-recent updates to a cache block. The algorithm only relies on one cache block, so it is very memory efficient – however, the arrival of the last thread triggers invalidations of all the cache block shared by all the other threads. These invalidations are immediately followed by another set of shared requests that produce the modified value that allows the threads to proceed, creating yet another thundering herd.

Figure 4-5 shows the source of a *sense-reversing* barrier with modifications made for clarity. A sense-reversing barrier solves a potential problem in naïvely implemented barriers by allowing threads to know whether they are in an “even” or “odd” phase of computation [21]. Each thread reverses its sense (stored in `threadsense`). Upon arrival, each thread atomically increments the counter, and all threads but the last thread spin on the `sense` variable to change. The last thread resets `count` and sets `sense`, waking up the other threads. Because the Tardis protocol allows sharers to read stale values, such a scheme may cause livelock in the absence of mechanisms



```

1 void barrier(int ncores)
2 {
3     static int sense;
4     static int count;
5     static __thread int threadsense;
6
7     memory_fence();
8
9     /* reverse my sense */
10    threadsense = !threadsense;
11
12    memory_fence();
13
14    /* see if i am the last arrival to the barrier */
15    if (fetch_and_add(count, 1) == ncores - 1) {
16        count = 0;
17        sense = threadsense;
18    } else {
19        /* spin until last arrival changes sense */
20        while (sense != threadsense);
21    }
22
23    memory_fence();
24 }

```

Figure 4-5: Source code for a sense-reversing barrier.

to periodically renew blocks. A barrier that wakes up waiting threads by invalidating exclusively-owned cache blocks appears in Figure 4-6.

In the barrier algorithm presented in Figure 4-6, all but the last arriving core spin on separate cache blocks. Once the last core arrives at the barrier, it writes to each cache block, triggering invalidations. In a directory-based protocol, spinning using ordinary loads – that is, without the use of atomic operations – will detect changes to the cache block. However, the Tardis implementation of the barrier uses the load-reserved instruction to assert exclusive ownership to detect changes to the cache block. In Figure 4-6, we use the load-reserved instruction to load the latest value of `threadsense` on lines 23 and 36.

The barrier implementations from Figures 4-5 and 4-6 use only one core to notify the rest – a *linear* barrier. *Tree* barriers, one of many barrier algorithms analyzed by Arenstorf and Jordan in [32], use multiple cores to inform other threads that they are permitted to leave the barrier. Although our barrier mechanism – invalidating

```

1  /* maximum number of cores possible on the system */
2  #define NCORES 16
3  #define BYTES_PER_CACHE_BLOCK 64
4  #define INTS_PER_CACHE_BLOCK (BYTES_PER_CACHE_BLOCK / sizeof(int))
5
6  int load_latest(int *m)
7  {
8      return load_reserved(m);
9  }
10
11 void barrier(int ncores)
12 {
13     /* maintain one cache block per core */
14     static int threadsense[NCORES][INTS_PER_CACHE_BLOCK];
15     static int count;
16
17     /* add to the counter and tell me when i arrived */
18     int me = fetch_and_add(count, 1);
19
20     memory_fence();
21
22     /* reverse my sense */
23     int phase = *threadsense[me];
24     int wanted = !phase;
25
26     memory_fence();
27
28     if (me == ncores - 1) {
29         /* last one resets count and wakes up other threads */
30         count = 0;
31         for (int i = 0; i < ncores; i++)
32             *threadsense[i] = wanted;
33     } else {
34         /* maintain exclusive ownership while spinning */
35         while (*threadsense[me] != wanted);
36     }
37
38     memory_fence();
39 }
40 }

```

Figure 4-6: Barrier exploiting the exclusive ownership state to notify other cores.

exclusively-owned blocks – is implemented in a linear fashion, tree barriers can be implemented analogously.

## Summary

Today’s synchronization primitives assume that multicore systems have directory-based cache coherence, but the Tardis protocols opens new possibilities for synchronization that operate independently of physical time. In particular, timestamps may obviate previously employed busy-waiting techniques. In this chapter, we reviewed two of many possible synchronization primitives and how to build them on a system implementing Tardis. In the next chapter, we discuss the hardware changes necessary to run these modified synchronization primitives.



# Chapter 5

## Implementation

We implemented a cycle-level simulator for the Tardis cache coherence protocol – the first we know of – on the Rocket Chip generator [15]. The Rocket Chip generator generates a configurable system with *Rocket* cores connected to outer-level caches and system environment (the “uncore”). The Rocket core is a six-stage, in-order scalar RISC-V processor that supports a supervisor implementation as well as 64- and 32-bit datapath widths. A four-stage pipelined non-blocking L1 data cache, the *HellaCache*, connects Rocket to the outer levels of the memory hierarchy. The outer memory hierarchies contain any number of L2 banks, which collectively serve as the last-level cache; these banks interface with DRAMSim2, a cycle-level simulator of main memory [33]. Rocket Chip is written in Chisel [34], a hardware design language embedded in Scala that generates C++ for cycle-level emulation or Verilog for FPGA synthesis and physical design.

In this chapter, we discuss our rationale for our design choices and the modifications required to the processor, network-on-chip, and coherence protocols needed to implement Tardis.

### 5.1 Guiding Principles

In the interest of simplicity and elegance, we chose not to expose timestamps to the programmer, so no instructions like “read timestamp” or “write timestamp” exist. As

a result, we add no new instructions to the instruction set. Furthermore, we retain binary compatibility. For the purposes of our evaluation, these features significantly simplify our task.

Recall that a set of timestamps  $\{ts_{\min}, ts_{\max}, ts_{\text{rel}}\}$  should be kept *per program* to prevent one program from prematurely expiring the cache blocks of other programs by performing too many memory fence operations. Implementations that expose timestamps to the programmer could rely on the operating system to modify the timestamps of individual cores to limit interference by other programs. However, introducing timestamps as additional microarchitectural state means that programmers must save and restore to the stack in the event of a context switch. Restoring incorrect timestamps could result in a program observing the wrong values in memory – something that would not occur in a conventional directory-based protocol. Because we prohibit cores from directly changing timestamps through software, all threads run with the same set of timestamps. Despite this limitation, our evaluation programs, which run without operating system facilities, do not degrade in performance due to this choice.

## 5.2 The RISC-V Rocket Microarchitecture

Implementing a client in the Tardis cache coherence protocol requires the addition of three timestamp counters:  $ts_{\text{rel}}$ ,  $ts_{\min}$ , and  $ts_{\max}$ . In a single-cycle core, the timestamps are always correct. Pipelining a processor, nowadays absolutely essential for performance and efficiency, complicates the implementation of the Tardis timestamps.

### 5.2.1 Pipelining Timestamps

Pipelining processors increases performance by reducing the clock period, but it introduces additional complexity because of the need for data bypasses and interlocking. The timestamps needed by Tardis are part of the processor’s microarchitectural state; although they are not directly accessible from software, the timestamps must be pipelined through the processor. An instruction earlier in the pipeline could oth-

erwise be affected by modifications to these timestamps by instructions ahead in the pipeline. Fortunately, release memory semantics allow operations to proceed out-of-order in the absence of memory fences or acquire/release instructions. This choice of memory model considerably simplifies Tardis-RC’s implementation, as Tardis-SC on a pipelined processor would require bypassing timestamps.

The Rocket microarchitecture stalls the decode stage if there is a fence instruction and remains stalled until the memory stage has completed all requests. Because we have stored timestamps at the decode stage, it is unnecessary to bypass timestamps. However, should timestamps be propagated into the execution units (such as in an out-of-order core or an aggressively pipelined in-order processor), updates to  $ts_{\min}$  would need to be bypassed to the memory unit to preserve the relaxed consistency model.

A processor’s timestamp counters only change when instructions commit, which parallels the semantics of all other instructions. This means that if a core takes an interrupt or encounters an exception, the instructions affected do not make updates to the timestamp. Conveniently, this requirement aligns with typical instruction commit semantics.

## 5.2.2 Extending the Memory Hierarchy

Many of the changes to needed to implement Tardis occur in the HellaCache and the outer levels of the memory hierarchy. We extended the metadata arrays in the HellaCache and the L2 to support the storage of the *wts* and *rts* timestamps. We extended the cache coherence protocol abstraction layer to define the Tardis protocol, which amounts to defining the effects of messages on the manager and client. Recognizing the diminished importance of leases and renewals in Tardis-RC, we set the lease to a fixed value of 10.

In the baseline implementation, a counter in the HellaCache tracks the number of cycles that have elapsed since the most recent load-reserved instruction. A store-conditional will fail if this counter exceeds 32 cycles. However, as we demonstrated in Section 3.2, the counter is not necessary; we eliminate the counter in the Tardis

implementation.

## 5.3 Network-on-Chip

Clients and managers communicate through the network-on-chip (NOC). Careful design reduces latency and avoids network-level deadlock. In this section, we discuss the NOC architecture as used in our implementation.

### 5.3.1 Manager/Client Abstraction

To facilitate the implementation of a variety of coherence protocols, Rocket Chip implements TileLink [35], a “cache coherence substrate” based on the architecture of Manager-Client Pairing (MCP) [36]. TileLink is an abstraction layer that supports hierarchical coherence protocol implementations. Clients and managers in this protocol communicate with five logical networks, as listed in Table 5-1.

| Network | Sent By | Tardis Messages                         |
|---------|---------|---|
| Acquire | Client  | SHARE, MODIFY, RENEW, UPGRADE requests  |
| Probe   | Manager | WRITEBACK requests                      |
| Release | Client  | WRITEBACK responses                     |
| Grant   | Manager | SHARE, MODIFY, RENEW, UPGRADE responses |
| Finish  | Client  | (not explicitly used by Tardis)         |

Table 5-1: Networks in the TileLink coherence protocol abstraction and mapping to the Tardis network messages listed in Table 2-4.

To prevent protocol-level deadlock, Tardis requires at least three logical channels: requests from the client, responses from the client, and messages from the manager [7]. (These are respectively called *c2pRq*, *c2pRp*, and *p2c*.) These three networks map cleanly to the Acquire, Release, and Probe/Grant networks used in TileLink<sup>1</sup>. The Finish network establishes message ordering. Tardis’s cache coherence logic fits cleanly into the TileLink abstraction, suggesting that Tardis requires no drastic changes to existing architectures. We augmented messages on the networks with

<sup>1</sup>The Acquire and Release TileLink networks have no relation to the acquire and release instructions of Section 2.3.



| Network | Sent By | Timestamps                    |
|---------|---------|-------------------------------|
| Acquire | Client  | Client's <i>pts</i>           |
| Probe   | Manager | none                          |
| Release | Client  | Cache block's <i>wts, rts</i> |
| Grant   | Manager | Cache block's <i>wts, rts</i> |
| Finish  | Client  | none                          |

Table 5-2: Timestamps required as part of a network message for an implementation of Tardis in the TileLink protocol.

Tardis's timestamps, as listed in Table 5-2. Other than these modifications, Tardis's cache coherence logic required no major changes to the TileLink architecture.

### 5.3.2 Network Topology

In the original Rocket Chip generator design, crossbars connect clients and managers. Each last-level cache bank requires one manager port on the crossbar, while each core requires two client ports. For low core counts, a crossbar is an acceptable network-on-chip. However, with many more cores, scaling the crossbar while maintaining low latency becomes untenable because only one manager-client pair may hold the network at a time. We chose to implement a mesh network to allow multiple messages to be in flight at a modest cost in complexity. We anticipate our future massively multicore systems will also use meshes.

Timestamps as wide as 64 bits may balloon the size of a message by 128 bits. The impact of timestamp size can be mitigated with compression as proposed in [6]. Timestamps may also be sent as separate packets in the same message to reduce network link width in exchange for a greater number of packets per message.

We selected the *xy algorithm*, a deterministic routing algorithm known for its simplicity and deadlock freedom, to route packets on the network. Currently, all packets carry header information, including the source and destination of a message, but wormhole flow control [37] can reduce the area needed by the network-on-chip by minimizing redundant routing information.

## Summary

In this chapter, we discussed the cycle-level emulator infrastructure and the minimal set of changes needed to implement Tardis on the Rocket Chip generator. Table 5-3 summarizes the system configuration. In the next chapter, we evaluate the performance of a system implementing Tardis to a baseline system with a number of microbenchmarks.

|                     |                            |
|---------------------|----------------------------|
| Cores               | 1 – 16                     |
| Microarchitecture   | Six-stage, in-order        |
| Cache block size    | 64 B                       |
| L1 cache size       | 16 KB                      |
| L1 cache parameters | 4 ways, random replacement |
| L2 banks            | 1 – 16                     |
| Protocol states     | MESI                       |
| L2 bank size, each  | 2048 KB                    |
| L2 cache parameters | 8 ways, random replacement |
| Main memory         | 1 GB, DRAMSim2             |

Table 5-3: System configurations of the Tardis implementation.

# Chapter 6

## Evaluation

In this chapter, we evaluate the performance of our implementation of Tardis-RC against a baseline implementation of a directory-based protocol in cycle-level simulation. We sweep from systems with one core to sixteen cores. Limitations in the simulator infrastructure made scaling systems to 32 cores and beyond impractical.

### 6.1 Atomic Instructions

We developed microbenchmarks to selectively exercise and evaluate the performance of the load-reserved/store-conditional (LR/SC) pair and atomic memory operations (AMOs). In these microbenchmarks, each core attempts to increment a counter using the aforementioned instructions. All microbenchmarks follow the pattern in Figure 6-1.

#### Compare-and-Swap

We do not implement or evaluate the performance of compare-and-swap (CAS), because the RISC-V architecture would require (1) substantial modifications to the memory system and (2) a three-ported register file to read a memory address, the comparison value, and the replacement value. Locking the bus from other cores, as the x86 architecture does [23], is not feasible with a system with hundreds or thou-

```

1 | static int count;
2 |
3 | void atomically_count()
4 | {
5 |     int i;
6 |
7 |     for (i = 0; i < 1000; i++)
8 |         count = count + 1; /* atomically */
9 |
10 |    barrier();
11 | }

```

Figure 6-1: Microbenchmark source code. All cores execute `atomically_count()` in parallel.

sands of cores connected on a mesh. Finally, the LR/SC instruction pair can emulate CAS and vice-versa [21].

## Load-Reserved/Store-Conditional

We use the LR/SC instruction pair to atomically increment a counter and then perform a barrier. We sweep the number of cores on the system from one to sixteen, and tabulate our results in Table 6-1.

|          | Cores |      |       |       |       |
|----------|-------|------|-------|-------|-------|
|          | 1     | 2    | 4     | 8     | 16    |
| Baseline | 11.1  | 54.8 | 107.5 | 222.9 | 451.7 |
| Tardis   | 11.1  | 53.8 | 150.4 | 223.0 | 462.9 |

Table 6-1: Average number of cycles required to increment a counter using load-reserved/store-conditional instructions as a function of core count, with the cost of a barrier amortized over 1,000 iterations.

In three of the five testing configurations, the results are largely the same. We observe slightly worse performance in Tardis because it allows invalidations to arrive at any time. Recall that the baseline implementation only invalidates cache blocks after executing the store-conditional instruction or after 32 cycles, whichever comes first.

We observe a 39.9% performance degradation in the four-core system, which re-

sults from a particularly low-performance combination of the arrival of a writeback request and Rocket’s branch predictor. Recall that cores must branch back to retry LR/SC sequence if the store-conditional fails. This pathological case illuminates a potential drawback of re-enabling invalidations to reach the cache in an LR/SC sequence: without access to *wts*, the branch predictor cannot reliably predict whether the store-conditional will succeed. In the baseline model, the execution of the load-reserved instruction practically guarantees the success of the following store-conditional instruction. In this case, the branch predictor will always predict the branch *not taken*.

Temporarily preventing invalidations, as done in the baseline model, can help improve performance by reducing hot spots on the network, implementing Tardis and checking *wts* offers an elegant solution. We allow programmers to guarantee the success of arbitrarily long LR/SC instruction sequences in the absence of interrupts and exceptions. In the baseline implementation, we have demonstrated that livelock occurs once the number of cycles between the load-reserved and store-conditional instructions exceeds 32; in the Tardis implementation, no such livelock occurs. Recall that the RISC-V ISA requires sixteen-instruction LR/SC sequences to succeed, and that Rocket’s 32-cycle counter attempts to implement this mandate. By using Tardis, we have not only eliminated the cycle counter but also reduced the ISA requirement to merely a performance optimization.

## Atomic Memory Operations

In Table 6-2, we show the results of using AMOs to atomically increment a counter on systems with one to sixteen cores, and then perform a barrier.

|          | Cores |     |      |      |      |
|----------|-------|-----|------|------|------|
|          | 1     | 2   | 4    | 8    | 16   |
| Baseline | 4.3   | 6.6 | 13.5 | 28.0 | 58.3 |
| Tardis   | 4.3   | 6.6 | 13.5 | 28.1 | 58.4 |

Table 6-2: Average number of cycles required to increment a counter using atomic memory operations.

Both implementations' performance on the AMO microbenchmark are practically identical. Because the L1 data cache performs atomic memory operations locally, exclusive ownership moves between cores in this microbenchmark. Performing AMOs at the last-level cache would keep the cache block data in one place.

Compared to LR/SC sequences, AMOs run much faster because of the design of the miss state handling registers (MSHRs). They allow multiple writes to the same cache block to be replayed in a burst once the cache block arrives at the data cache. The LR/SC instruction pair cannot be replayed in this manner, as the core must check whether the store-conditional instruction succeeded.

When operations on a shared variable commute, AMOs are an attractive choice; LR/SC instruction sequences offer greater flexibility in the way a core may modify memory atomically.

## 6.2 Synchronization Primitives

We also developed microbenchmarks to evaluate the performance of the Mellor-Crummey-Scott (MCS) queue lock and a sense-reversing barrier. On this implementation of the Tardis protocol, an ordinary spin lock would cause livelock, so we do not examine it here.

### MCS Queue Lock

In this microbenchmark, we use the MCS queue lock to acquire a lock on a shared memory variable, and then increment the shared memory variable. Figure 6-2 shows the number of cycles required for each core to increment the counter 1,000 times and perform the barrier. To minimize false sharing, each core stores its local copy of the queue lock node in separate cache blocks.

As expected, running the code on single-core systems yields identical results. As the core count increases, both implementations remain well-matched as they both rely on invalidating cache blocks located at other cores. The bars represent how much time it takes for the other  $(n - 1)$  cores on an  $n$ -core system to acquire and release the

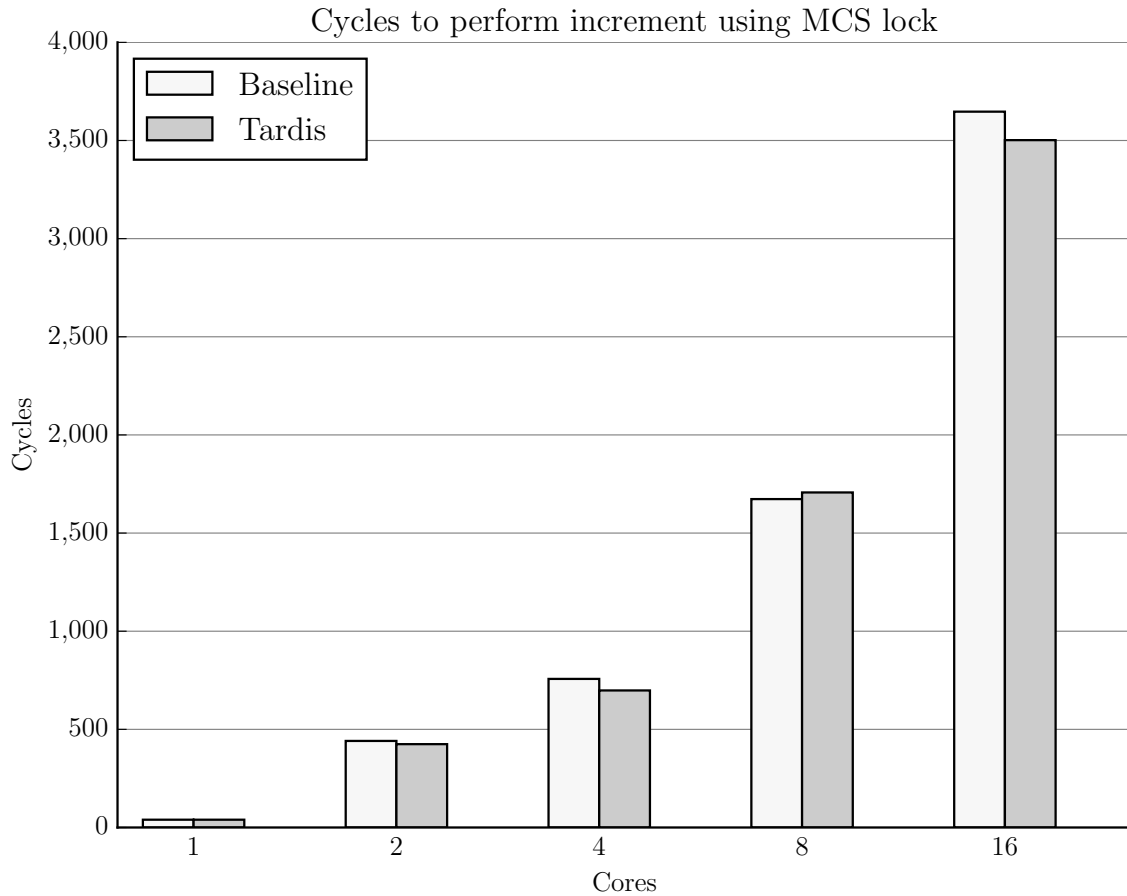

Figure 6-2: Performance of the MCS queue lock on a microbenchmark that atomically increments a variable.

lock. As a result, we see an exponential increase in wait time commensurate with the exponential increase in core count.

## Barrier

In this microbenchmark, cores complete consecutive barriers, and we measure the average time required to complete one barrier. Figure 6-3 shows the performance of two barrier implementations on the Tardis and baseline systems.

The measurements suggest at least two observations: at higher core counts, the scalability of a sense-reversing barrier degrades much more rapidly than one that employs exclusive ownership. The Tardis and directory protocols do not fundamentally differ in their use of the exclusively owned state, so we do not see significant

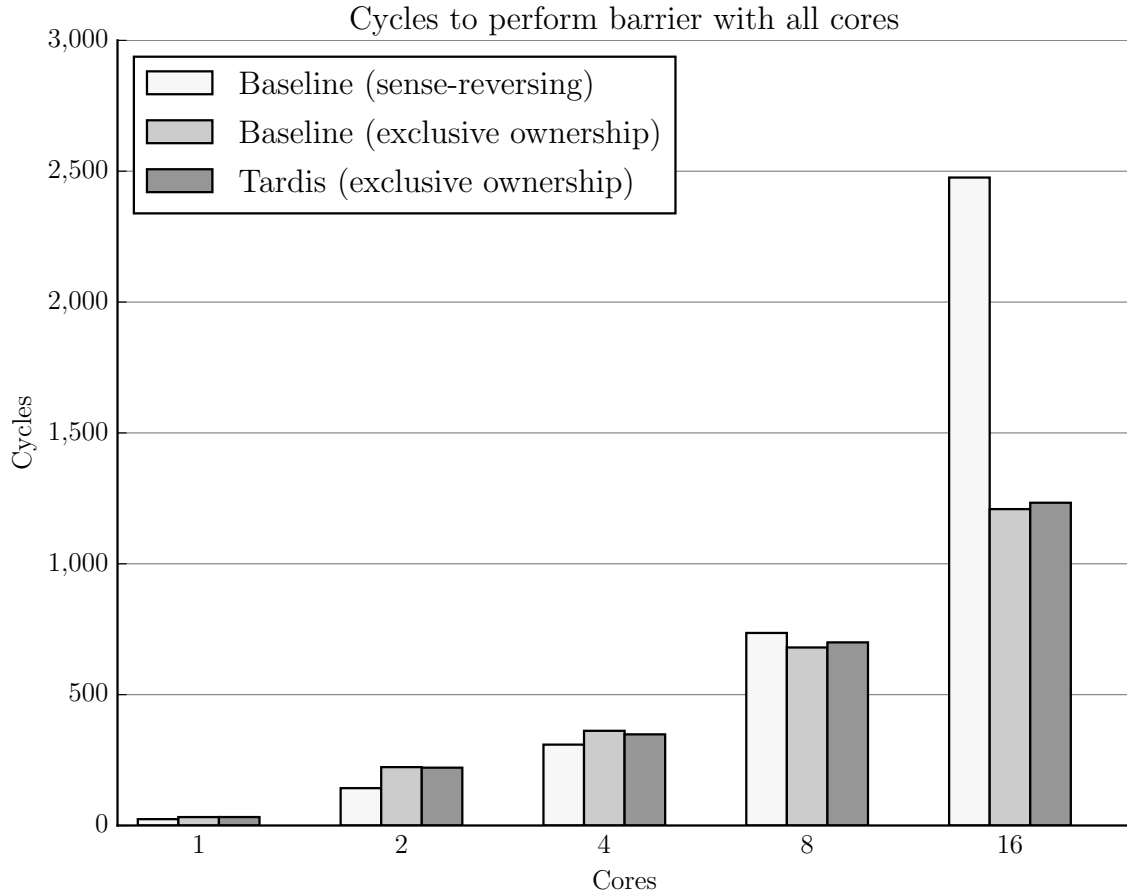

Figure 6-3: Performance of a barrier microbenchmark.

differences in the performance of the second barrier. As our implementation does not automatically increment timestamps, a sense-reversing barrier that relies on spinning would cause livelock on the Tardis system.

### 6.3 Application Performance

In this section, we examine the performance of two simple applications: vector-vector addition and matrix-matrix multiplication. Although they do not specifically target the synchronization primitives, these benchmarks show that Tardis has comparable performance to the directory-based baseline.



## Vector-Vector Addition

This benchmark measures the number of cycles needed for the cores to element-wise add two vectors together. In the *in-place* version of the benchmark, the sum is placed in one of the input vectors; in the *out-of-place* version, the sum is placed in a separate vector. The following performance results are collected by performing the out-of-place addition first and the in-place addition second. As the out-of-place addition will have cached some data at the cores, the second addition will take place with “warm” caches, so we expect a modest performance improvement.

The first version of the benchmark structures the memory access pattern of both the out-of-place and in-place additions to exhibit *false sharing*, in which different cores access different addresses in the same cache block. This causes high network traffic and latency as exclusive ownership of the cache block “ping-pongs” between cores. Figure 6-4 shows results for vector-vector addition with deliberate false sharing.

In the single-core case, no false sharing actually occurs, so the bound on performance depends on the cache parameters as well as network latencies. At lower core counts, renewal traffic caused by memory fences decreases Tardis’s system performance by 4.6% for the out-of-place and 14.6% for the in-place versions on the single-core system. As the number of cores increases, we find less-than-linear speedup due to false sharing. Furthermore, the number of invalidations needed for the baseline directory protocol increase. At higher core counts, invalidations force the baseline system to request more cache blocks than the Tardis system, yielding Tardis a modest advantage over the baseline protocol.

Performance significantly increases in the sixteen-core version because the interleaved accesses now straddle two cache blocks. Each 64-byte cache block contains eight double-precision floating-point numbers. Although false sharing persists in this benchmark, accesses to any cache block now originate from one of two groups of eight cores.

The other version of the vector-vector addition benchmark divides work to avoid false sharing, leaving the benchmarks only to the eviction rates and, in Tardis’s case,

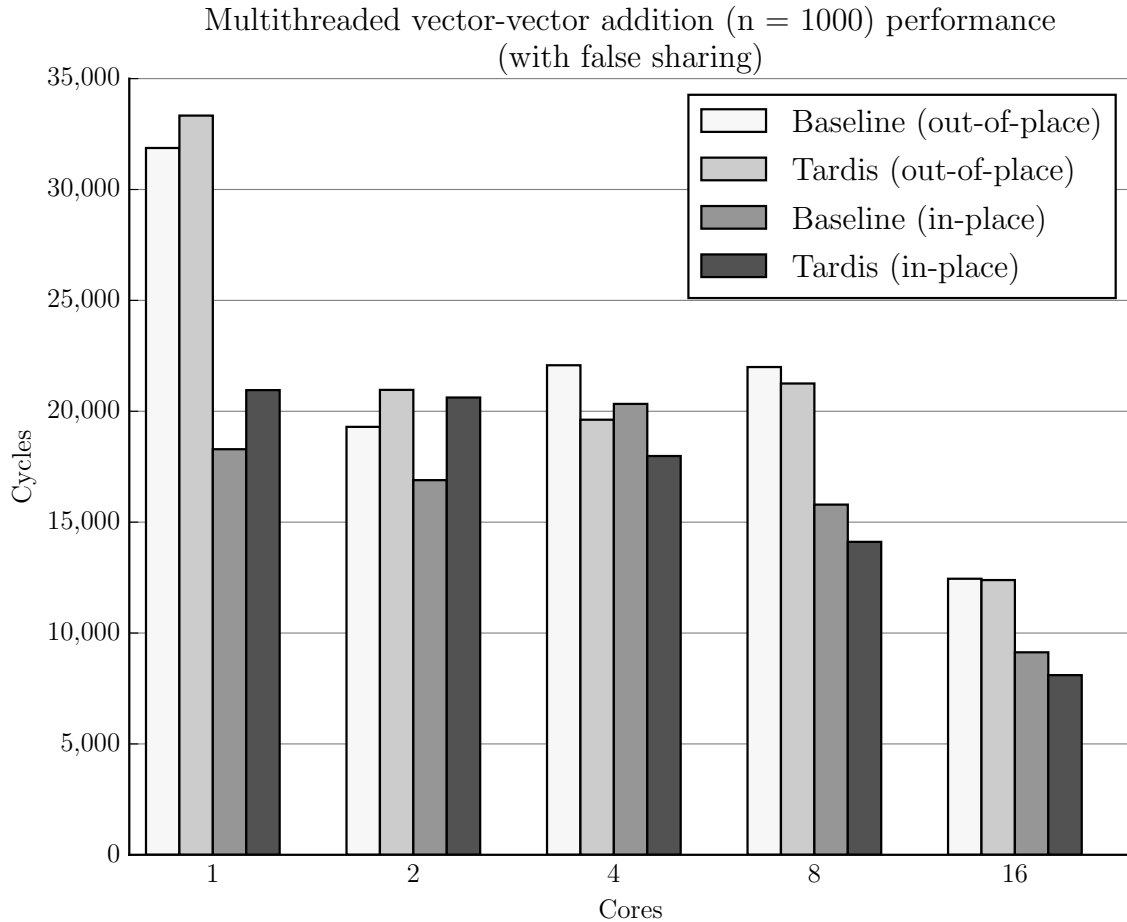

Figure 6-4: Performance of a vector-vector add benchmark exhibiting false sharing.

renewals. Figure 6-5 shows results for vector-vector addition without deliberate false sharing.

In the single-core case, just as before, renewals degrades performance on the Tardis system by 6.9% for the out-of-place and 12.8% for the in-place versions, respectively. The Tardis implementation outperforms the baseline implementation by 19.4% on the sixteen-core system. At higher core counts, the number of invalidations issued for the baseline system exceeds the number issued by the Tardis protocol. Furthermore, the baseline system sees a modest increase in the number of cache blocks requested from the last-level cache.

To learn more about the performance discrepancies, we count the number of Acquire messages – requests for cache blocks – sent on the network in Figure 6-6 (with

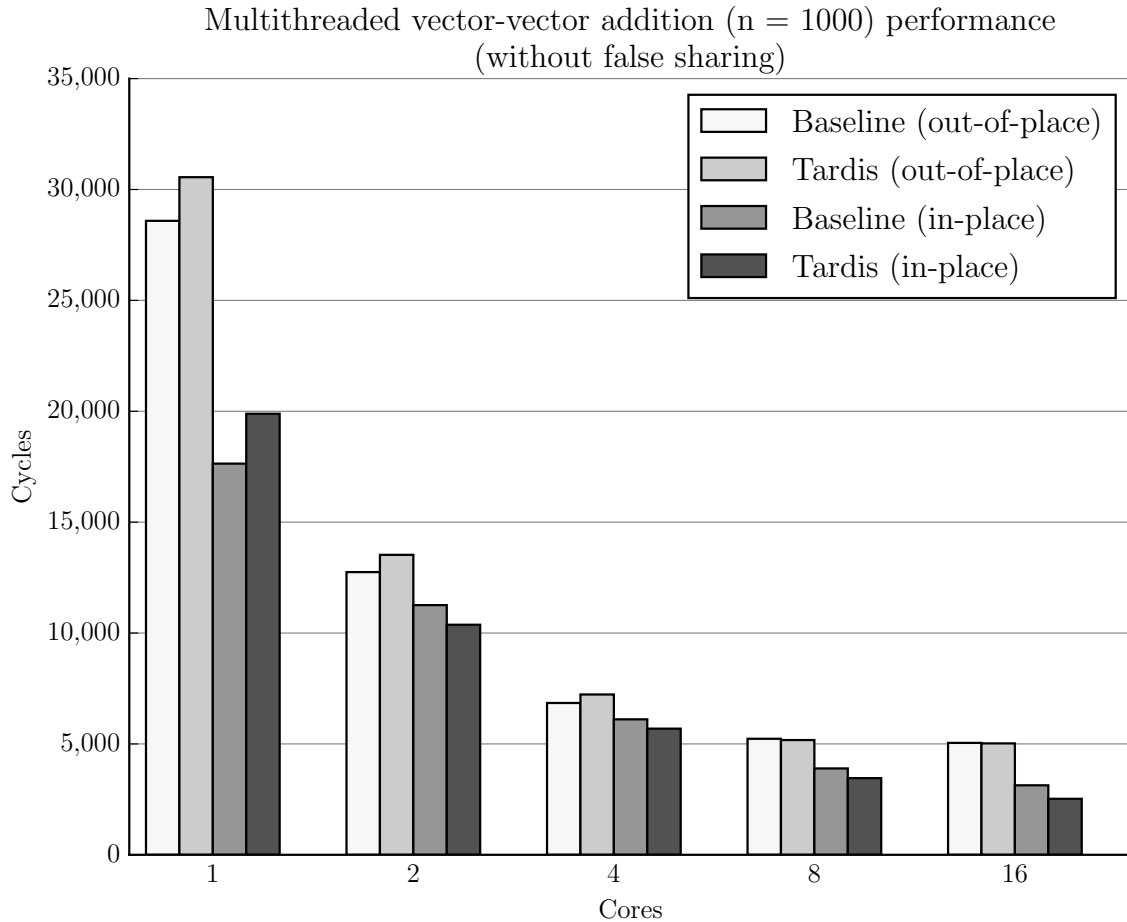

Figure 6-5: Performance of a vector-vector addition benchmark without false sharing.

false sharing) and Figure 6-7 (without false sharing). For the Tardis protocol, we also show the fraction of Acquire messages that are renewals for this benchmark. (The out-of-place vector-vector addition occurs does not follow any fences, so no renewals occur.)

Despite the number of renewals, the number of acquire messages sent during in-place addition remain almost consistently lower for Tardis than the baseline, especially for the 2-, 4-, and 8-core systems. The time needed to service these requests increases benchmark completion time compared to the baseline system. Figure 6-7 shows the number of Acquire messages in the vector-vector addition benchmark without false sharing.

As expected, the number of requests sharply drops when cores work without inval-

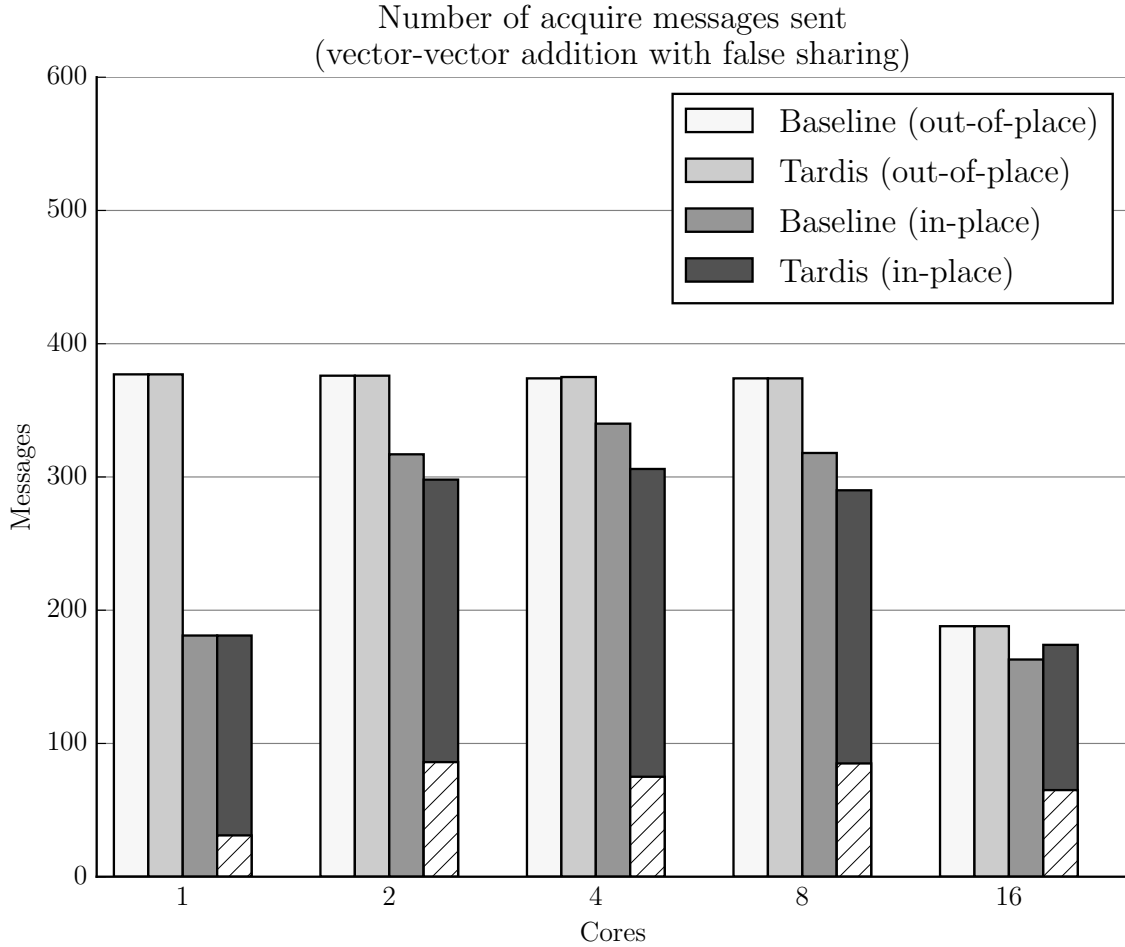

Figure 6-6: Number of messages sent on the Acquire TileLink network during the vector-vector addition benchmark with false sharing. For the in-place addition on Tardis, the hatched white bar represents the fraction of requests that are renewals. Tardis, the fraction of which are renewals.

identifying each others' cache blocks. At core counts of 8 and 16, it appears that renewal traffic on Tardis matches or exceeds the traffic incurred by the baseline. As the core count increases, the vectors become shorter, but renewals must happen because of the memory fence occurring between the out-of-place and in-place additions.

## Matrix-Matrix Multiplication

In this benchmark, cores naïvely multiply (*i.e.*, not with the Strassen algorithm) two 32 by 32 element matrices in parallel. This benchmark exercises the memory system

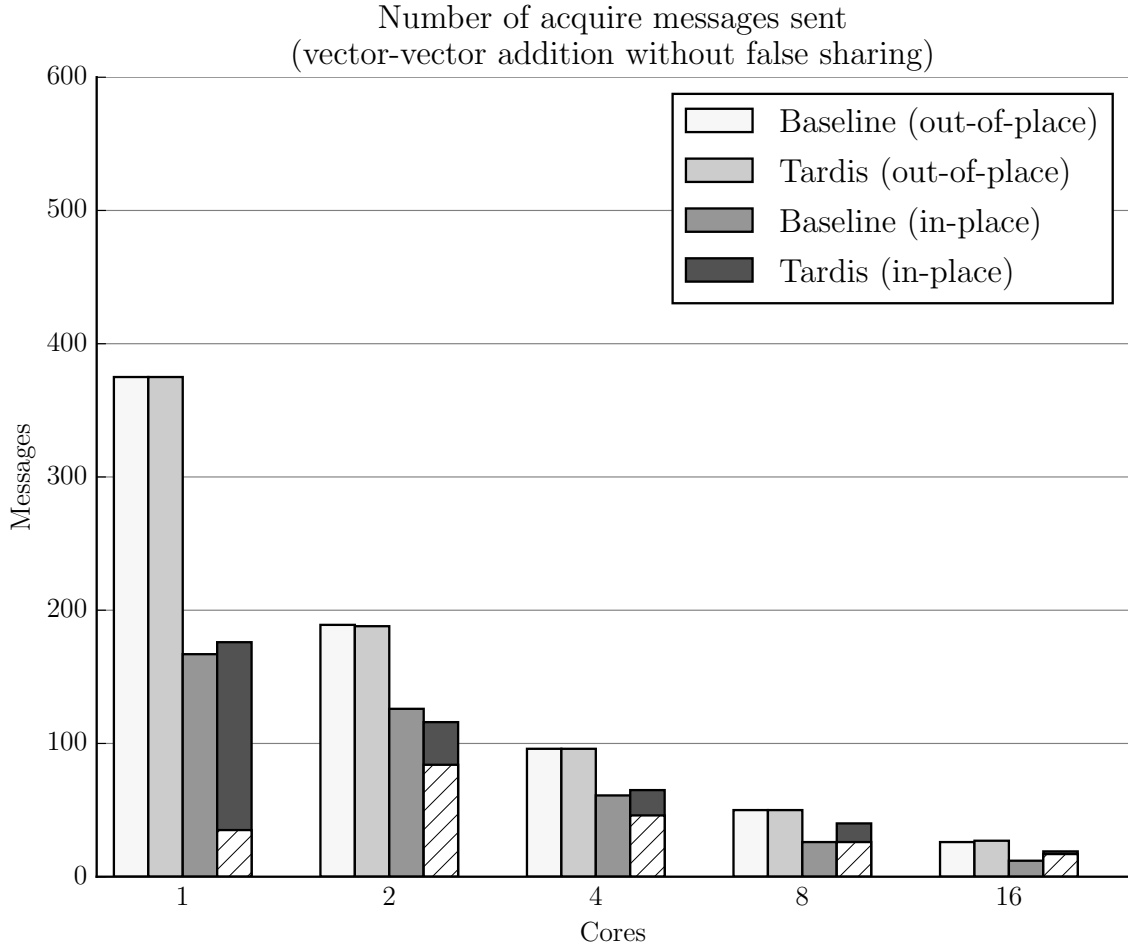

Figure 6-7: Number of messages sent on the Acquire TileLink network during the vector-vector addition benchmark without false sharing. For the in-place addition on Tardis, the hatched white bar represents the fraction of requests are renewals.

under heavy read and relatively light write loads. Figure 6-8 shows the cycles required to complete a matrix-matrix multiplication on the baseline and Tardis systems.

As we expect with an embarrassingly parallel benchmark, we achieve nearly perfect speedup in runtime, tempered only by overhead from processes like synchronization. In both vector-vector addition and matrix-matrix multiplication, the Tardis implementations perform very comparably to the baseline measurements.

As we observed in the vector-vector addition benchmarks, a source of performance degradation arises from renewals, although Tardis-RC eliminates many of the renewals that Tardis-SC would have incurred. Renewals hinder performance on (1) single-core systems and (2) systems that perform relatively few operations but many memory

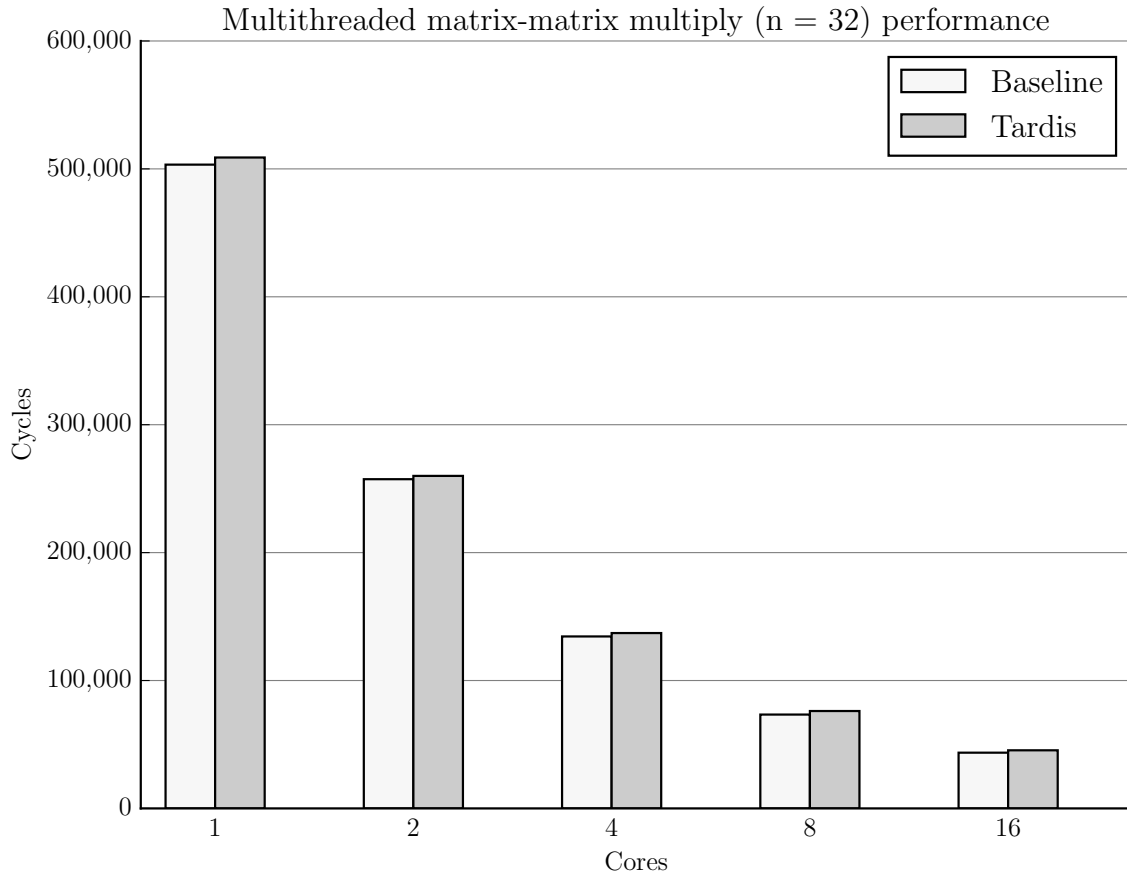

Figure 6-8: Performance of a matrix-matrix multiplication.

fences. We observed the second effect as we scaled the vector-vector addition without false sharing to 8 and 16 cores.

Although these applications use synchronization only peripherally, these results demonstrate that implementing the Tardis protocol is not only feasible but also practical.

## Summary

In this chapter, we compared the performance of the Tardis cache coherence protocol to a baseline directory protocol using several microbenchmarks. In most cases, the Tardis protocol performed just as well as the baseline. We found that differences in performance arise from cache block renewals and conditions on the on-chip network.

Despite the need for renewals in our applications, we saw that renewals become less relevant in hampering overall protocol performance. We also find that renewals, once a significant consideration in Tardis-SC, become diminished in relevance in Tardis-RC. This evaluation yields many insights that can steer future inquiries into timestamp-based coherence protocols.





# Chapter 7

## Conclusion

This thesis examined Tardis in sequentially-consistent and release-consistent variants. We devised new atomic instructions to take advantage of Tardis's timestamps and used them to construct commonly-used synchronization primitives. We demonstrated that the Tardis implementations perform nearly as well as our baseline system.

### 7.1 Future Work

We have only taken a glimpse at the unique possibilities offered by timestamp-based cache coherence protocols like Tardis, and there is plenty of room for future work.

The Tardis invariant links the write timestamp to the value of the data. In this thesis, we used it to eliminate the ABA problem in compare-and-swap and the livelock problem in load-reserved/store-conditional sequences. Linking physiological time to data will yield yet more innovation.

Currently, the only way to obtain the latest value of data in a cache is to load it in the exclusive state (accomplished in our implementation with the load-reserved instruction). We hope to find other ways of explicitly loading the latest value of a cache block while minimizing cache invalidations. Ideally, we would establish some mechanism to notify cores of an updated value and allow them to sleep or yield to the operating system to schedule another process.

The prototype implementation has several shortcomings that hinder its practical-

ity. In each core, fully implementing the finer-grained timestamps –  $wts_{\min}$ ,  $wts_{\max}$ ,  $rts_{\min}$ , and  $rts_{\max}$  in lieu of  $ts_{\min}$  and  $ts_{\max}$  – would align Rocket’s microarchitecture to fully exploit the relaxations allowed by release consistency, but Rocket would also need to be extended to make full use of these features.

Currently, all clients and managers have a mesh node on the network. Each client and manager has its own node on the mesh, which is somewhat sub-optimal. We plan to move to a tiled architecture, in which each node contains a core, its L1 cache, and slice of the last-level cache, to reduce the number of routers and nodes on the main network. All packets on the network, regardless of overall message length, contain routing header information. With wormhole routing, we can dispense with all but one of the copies of the header, and subsequently narrow the networks. To reduce network area, we may merge logical networks which see relatively little traffic, like the Probe and Grant networks.

Our evaluation uses microbenchmarks to individually evaluate the performance of atomic instructions and synchronization primitives. A logical extension is to diverse applications that measure realistic uses of the instructions and primitives covered in this thesis. Synchronization plays a crucial role in operating system performance, so incorporating physiological time may yield performance and scalability benefits. Of course, synchronization is not the only bottleneck – today’s programming paradigms make deep-seated assumptions about the underlying system architecture. To take advantage of Tardis’s properties, we should find algorithms best-suited for scaling to systems with thousands of cores. For instance, lock-free algorithms can reduce the waiting ordinarily incurred by conventional synchronization primitives.

Our immediate future work involves the extension of this work towards the construction of a thousand-core system<sup>1</sup> with logic distributed throughout several interconnected FPGAs. Accordingly, we will optimize our design for FPGA synthesis, including the elimination of any critical paths in the design. We especially want to optimize the network-on-chip, as we have yet to synthesize it. In particular, we would

---

<sup>1</sup>The system is tentatively named T-1000, the time-traveling antagonist in *Terminator 2: Judgment Day* (1991).

like to demonstrate a minimum of additional complexity and modest area<sup>2</sup> and power requirements.

## 7.2 Concluding Remarks

We will need a variety of techniques to build computers that satisfy strict constraints on performance, power, and complexity. Tardis removes a major impediment to the scaling of multiprocessor systems. Some efforts can be devoted to increasing the number of cores on a single die. Others can extend the ideas from Tardis to other domains. We will need to rethink the way concurrent applications run today to meet the demands of the future. It's not *just* about time; it's about *physiological time*.

---

<sup>2</sup>To prove that a system implementing Tardis is not bigger on the inside.



# Bibliography

- [1] J. L. Hennessy and D. A. Patterson, *Computer Architecture: A Quantitative Approach*. Elsevier, 2011.
- [2] E. Gardner, “What public disclosures has Intel made about Knights Landing?” November 2014. [Online]. Available: <https://software.intel.com/en-us/articles/what-disclosures-has-intel-made-about-knights-landing>
- [3] D. Chaiken, J. Kubiawicz, and A. Agarwal, “LimitLESS Directories: A scalable cache coherence scheme,” *SIGPLAN Not.*, vol. 26, no. 4, pp. 224–234, Apr. 1991. [Online]. Available: <http://doi.acm.org/10.1145/106973.106995>
- [4] D. Chaiken, C. Fields, K. Kurihara, and A. Agarwal, “Directory-based cache coherence in large-scale multiprocessors,” *Computer*, vol. 23, no. 6, pp. 49–58, June 1990.
- [5] Y.-C. Maa, D. K. Pradhan, and D. Thiebaut, “Two economical directory schemes for large-scale cache coherent multiprocessors,” *SIGARCH Comput. Archit. News*, vol. 19, no. 5, pp. 10–, Sep. 1991. [Online]. Available: <http://doi.acm.org/10.1145/379189.379198>
- [6] X. Yu and S. Devadas, “Tardis: Time Traveling Coherence Algorithm for Distributed Shared Memory,” *CoRR*, vol. abs/1501.04504, 2015. [Online]. Available: <http://arxiv.org/abs/1501.04504>
- [7] X. Yu, M. Vijayaraghavan, and S. Devadas, “A proof of correctness for the tardis cache coherence protocol,” *CoRR*, vol. abs/1505.06459, 2015. [Online]. Available: <http://arxiv.org/abs/1505.06459>
- [8] J. Miller, H. Kasture, G. Kurian, C. Gruenwald, N. Beckmann, C. Celio, J. Eastep, and A. Agarwal, “Graphite: A distributed parallel simulator for multicores,” in *High Performance Computer Architecture (HPCA), 2010 IEEE 16th International Symposium on*, Jan 2010, pp. 1–12.
- [9] M. S. Papamarcos and J. H. Patel, “A low-overhead coherence solution for multiprocessors with private cache memories,” in *ACM SIGARCH Computer Architecture News*, vol. 12, no. 3. ACM, 1984, pp. 348–354.
- [10] *Doctor Who*, “Blink,” episode 10, originally aired June 9, 2007.

- [11] L. Lamport, “Time, clocks, and the ordering of events in a distributed system,” *Commun. ACM*, vol. 21, no. 7, pp. 558–565, Jul. 1978. [Online]. Available: <http://doi.acm.org/10.1145/359545.359563>
- [12] —, “How to make a multiprocessor computer that correctly executes multiprocess programs,” *Computers, IEEE Transactions on*, vol. 100, no. 9, pp. 690–691, 1979.
- [13] K. Gharachorloo, D. Lenoski, J. Laudon, P. Gibbons, A. Gupta, and J. Hennessy, “Memory consistency and event ordering in scalable shared-memory multiprocessors,” in *Proceedings of the 17th Annual International Symposium on Computer Architecture*, ser. ISCA ’90. New York, NY, USA: ACM, 1990, pp. 15–26. [Online]. Available: <http://doi.acm.org/10.1145/325164.325102>
- [14] S. V. Adve and K. Gharachorloo, “Shared memory consistency models: a tutorial,” *Computer*, vol. 29, no. 12, pp. 66–76, Dec 1996.
- [15] K. Asanović, R. Avizienis, J. Bachrach, S. Beamer, D. Biancolin, C. Celio, H. Cook, D. Dabbelt, J. Hauser, A. Izraelevitz, S. Karandikar, B. Keller, D. Kim, J. Koenig, Y. Lee, E. Love, M. Maas, A. Magyar, H. Mao, M. Moreto, A. Ou, D. A. Patterson, B. Richards, C. Schmidt, S. Twigg, H. Vo, and A. Waterman, “The Rocket Chip generator,” EECS Department, University of California, Berkeley, Tech. Rep. UCB/EECS-2016-17, Apr 2016. [Online]. Available: <http://www.eecs.berkeley.edu/Pubs/TechRpts/2016/EECS-2016-17.html>
- [16] A. Waterman, “Design of the risc-v instruction set architecture,” Ph.D. dissertation, EECS Department, University of California, Berkeley, Jan 2016. [Online]. Available: <http://www.eecs.berkeley.edu/Pubs/TechRpts/2016/EECS-2016-1.html>
- [17] P. L. Reiher, J. S. Heidemann, D. Ratner, G. Skinner, and G. J. Popek, “Resolving file conflicts in the Ficus file system,” in *Summer USENIX Conference, Proceedings of the*, June 1994, pp. 183–195.
- [18] D. B. Terry, M. M. Theimer, K. Petersen, A. J. Demers, M. J. Spreitzer, and C. H. Hauser, “Managing update conflicts in Bayou, a weakly connected replicated storage system,” in *ACM Symposium on Operating Systems Principles, Proceedings of the 15th*, December 1995.
- [19] P. Keleher, A. L. Cox, S. Dwarkadas, and W. Zwaenepoel, “Treadmarks: Distributed shared memory on standard workstations and operating systems,” in *USENIX Winter*, vol. 1994, 1994, pp. 23–36.
- [20] J. C. Corbett, J. Dean, M. Epstein, A. Fikes, C. Frost, J. J. Furman, S. Ghemawat, A. Gubarev, C. Heiser, P. Hochschild *et al.*, “Spanner: Google’s globally distributed database,” *ACM Transactions on Computer Systems (TOCS)*, vol. 31, no. 3, p. 8, 2013.

- [21] M. Herlihy and N. Shavit, *The Art of Multiprocessor Programming, Revised Reprint*. Elsevier, 2012.
- [22] R. P. Case and A. Padege, “Architecture of the IBM System/370,” *Commun. ACM*, vol. 21, no. 1, pp. 73–96, Jan. 1978. [Online]. Available: <http://doi.acm.org/10.1145/359327.359337>
- [23] *Intel 64 and IA-32 Architectures Software Developer’s Manual*. Intel Corporation, April 2016, vol. 2 (2A, 2B & 2C).
- [24] E. H. Jensen, G. W. Hagensen, and J. M. Broughton, “A new approach to exclusive data access in shared memory multiprocessors,” Technical Report UCRL-97663, Lawrence Livermore National Laboratory, Tech. Rep., 1987.
- [25] S. Steely, S. Van Doren, and M. Sharma, “Livelock prevention by delaying surrender of ownership upon intervening ownership request during load locked / store conditional atomic memory operation,” Oct. 5 2004, uS Patent 6,801,986. [Online]. Available: <https://www.google.com/patents/US6801986>
- [26] C. P. Kruskal, L. Rudolph, and M. Snir, “Efficient synchronization of multiprocessors with shared memory,” *ACM Trans. Program. Lang. Syst.*, vol. 10, no. 4, pp. 579–601, Oct. 1988. [Online]. Available: <http://doi.acm.org/10.1145/48022.48024>
- [27] J. R. Goodman, M. K. Vernon, and P. J. Woest, “Efficient synchronization primitives for large-scale cache-coherent multiprocessors,” in *Proceedings of the Third International Conference on Architectural Support for Programming Languages and Operating Systems*, ser. ASPLOS III. New York, NY, USA: ACM, 1989, pp. 64–75. [Online]. Available: <http://doi.acm.org/10.1145/70082.68188>
- [28] T. David, R. Guerraoui, and V. Trigonakis, “Everything you always wanted to know about synchronization but were afraid to ask,” in *Proceedings of the Twenty-Fourth ACM Symposium on Operating Systems Principles*, ser. SOSP ’13. New York, NY, USA: ACM, 2013, pp. 33–48. [Online]. Available: <http://doi.acm.org/10.1145/2517349.2522714>
- [29] “The Jargon File,” version 4.4.7. [Online]. Available: <http://www.catb.org/jargon/html/T/thundering-herd-problem.html>
- [30] J. M. Mellor-Crummey and M. L. Scott, “Algorithms for scalable synchronization on shared-memory multiprocessors,” *ACM Trans. Comput. Syst.*, vol. 9, no. 1, pp. 21–65, Feb. 1991. [Online]. Available: <http://doi.acm.org/10.1145/103727.103729>
- [31] S. Boyd-Wickizer, M. F. Kaashoek, R. Morris, and N. Zeldovich, “Non-scalable locks are dangerous,” in *Proceedings of the Linux Symposium*, 2012, pp. 119–130.
- [32] N. S. Arenstorf and H. F. Jordan, “Comparing barrier algorithms,” *Parallel Computing*, vol. 12, no. 2, pp. 157–170, 1989.

- [33] P. Rosenfeld, E. Cooper-Balis, and B. Jacob, “DRAMSim2: A cycle accurate memory system simulator,” *IEEE Computer Architecture Letters*, vol. 10, no. 1, pp. 16–19, Jan 2011.
- [34] J. Bachrach, H. Vo, B. Richards, Y. Lee, A. Waterman, R. Avižienis, J. Wawrzynek, and K. Asanović, “Chisel: Constructing Hardware in a Scala Embedded Language,” in *Proceedings of the 49th Annual Design Automation Conference*. ACM, 2012, pp. 1216–1225.
- [35] H. Cook, “TileLink 0.3.3 specification.” [Online]. Available: [https://docs.google.com/document/d/1Iczcjgc-LUi8QmDPwnAu1kH4Rrt6Kqi1\\_EUaCrfrk8/pub](https://docs.google.com/document/d/1Iczcjgc-LUi8QmDPwnAu1kH4Rrt6Kqi1_EUaCrfrk8/pub)
- [36] J. G. Beu, M. C. Rosier, and T. M. Conte, “Manager-client pairing: a framework for implementing coherence hierarchies,” in *Proceedings of the 44th Annual IEEE/ACM International Symposium on Microarchitecture*. ACM, 2011, pp. 226–236.
- [37] W. J. Dally and B. P. Towles, *Principles and Practices of Interconnection Networks*. Elsevier, 2004.