

The Case for Malleable Stream Architectures

Christopher Batten^{1,3}, Hidetaka Aoki², Krste Asanović³

¹ Department of Electrical Engineering and Computer Science
Massachusetts Institute of Technology, Cambridge, MA

² Central Research Laboratory
Hitachi, Ltd., Tokyo, Japan

³ Department of Electrical Engineering and Computer Science
University of California, Berkeley, CA

Workshop on Streaming Systems
November 8, 2008

Key Characteristics of Stream Programs

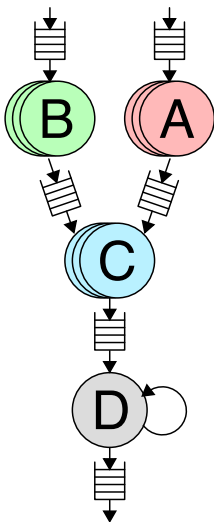

Types of Parallelism

- DLP : Data-Level Parallelism
- KLP : Task-Level Parallelism
- KLP : Pipeline Parallelism

Other Characteristics

- Data-dependent control flow
- Communication patterns
- Real-time constraints

Mapping Stream Programs to Stream Architectures

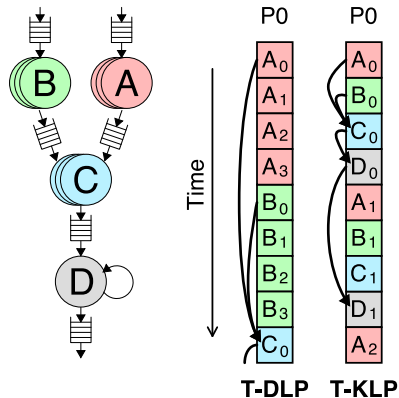

Temporal Data-Level Parallelism

Temporal Kernel-Level Parallelism

Mapping Stream Programs to Stream Architectures

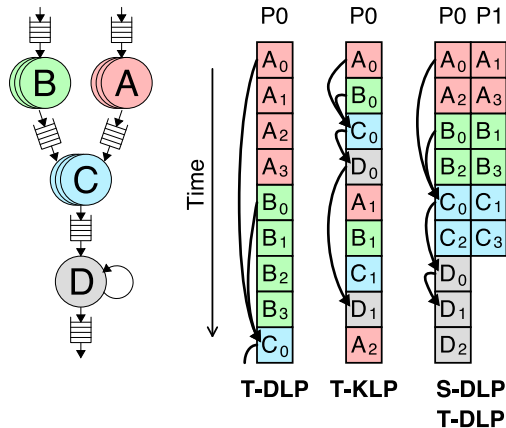

Temporal Data-Level Parallelism

Spatial Data-Level Parallelism

Temporal Kernel-Level Parallelism

Mapping Stream Programs to Stream Architectures

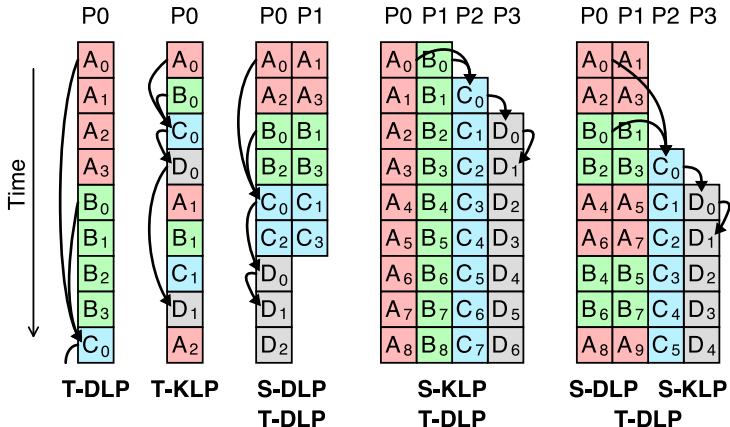
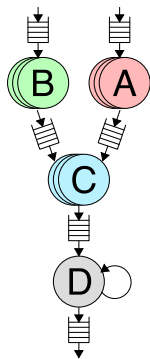

Temporal Data-Level Parallelism

Spatial Data-Level Parallelism

Temporal Kernel-Level Parallelism

Spatial Kernel-Level Parallelism

Comparison of Stream Program Mappings

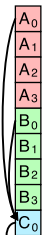

Temporal DLP

- Temporally amortize control & synchronization overheads
- Efficiently saturate off-chip memory bandwidth

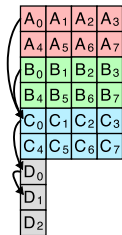

Spatial DLP

- Spatially amortize control & synchronization overheads
- Efficiently saturate off-chip memory bandwidth
- Trivial load-balancing assuming no data-dependent control flow

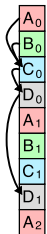

Temporal KLP

- Exploit producer-consumer locality to reduce buffering
- Reduce per-element latency



Spatial KLP

- Exploit producer-consumer locality to reduce buffering
- Reduce per-element latency
- Easy to map data-dependent control flow
- Good utilization for stateful kernels

Example Stream Processors

NVIDIA GTX 200

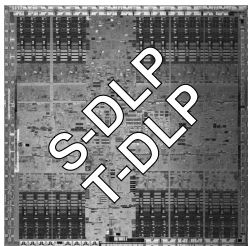

- 30 Cores
- 8 Lane Vector Units
- Inter-kernel buffering usually stored in DRAM
- Difficult to exploit KLP spatially

SPI Storm-1

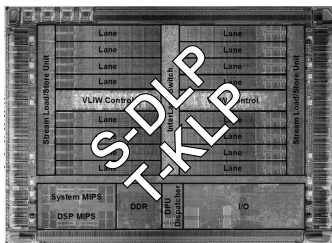

- 1 Core
- 16 Lane Vector Unit
- 32b Subword SIMD
- Inter-kernel buffering blocked in stream register file
- Cannot exploit KLP spatially

Tilera TILE64

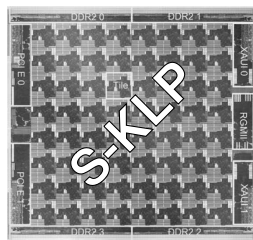

- 64 Cores
- 32b Subword SIMD
- Inter-kernel buffering routed through static network

Our Position: Exploit DLP First Then KLP

Programmers and architects should first leverage
DLP execution whenever possible

Energy Efficiency • Memory Bandwidth Utiliation • Load Balancing

Our Position: Exploit DLP First Then KLP

Programmers and architects should first leverage
DLP execution whenever possible

Energy Efficiency • Memory Bandwidth Utiliation • Load Balancing

Programmers and architects must still be able to
efficiently exploit KLP, but only after DLP

Minimize Buffering • Reduce Latency • Data-Dependent Conditionals

Maven: Malleable Array of Vector-Thread Engines

